



DRIVING CHANGE

Crossover Zoning Wiring Instructions

Summary

System Overview

- Zone Board (ZONEBB4CN01)
 - Powering Zone Board
- Supply Air Sensor
- Thermostat Wiring
- Dump Zone

Phase Updates

- Equipment used in lab testing
- System Wiring
 - Indoor Unit Wiring
 - Outdoor Unit Wiring



Bryant Preferred™ Four-Zone Board

Control boards are the “brains” of the zoning system – they receive heat or cool calls from the thermostat, then turn on the HVAC system and controls the dampers so that only the appropriate zone gets heated or cooled

ZONEBB4CN01
(four zone)

Connectors
from
Thermostats

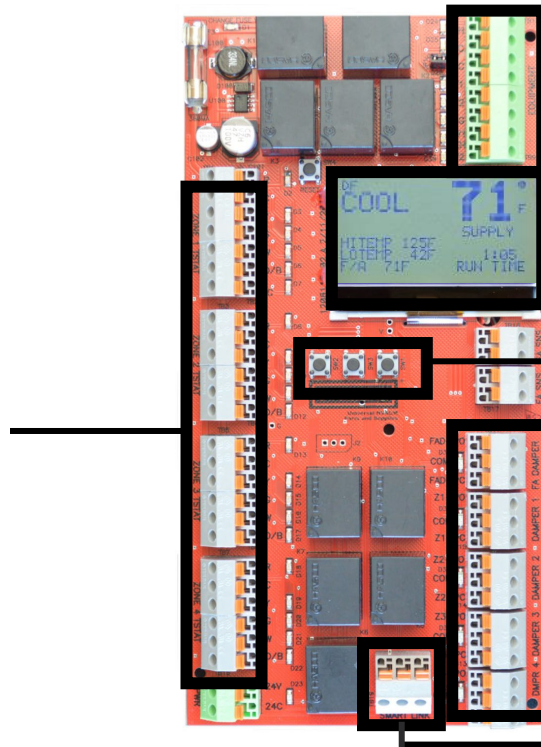

Connector to
HVAC

Display
Screen

Pushbutton Controls

Connectors to Dampers

Expansion connector (connect more
boards for more zones)



Wiring Diagram - Power Zoning Controller

ZONEBB4CN01 Zone Controller

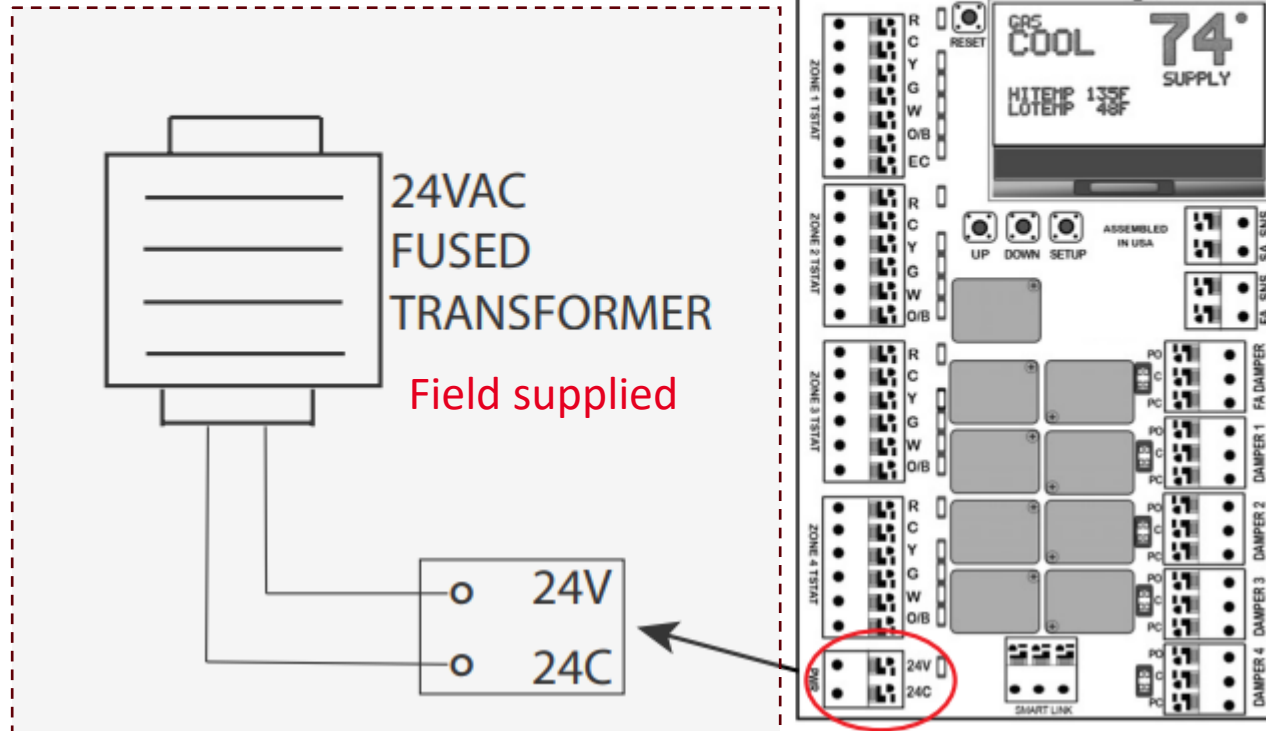

Follow Zone Controller
Installation Instructions

Table 1 - Ratings

Input Ratings	Voltage: 18-40 VAC 50/60 HZ transformer of 40 VA or more
Current Draw	<ul style="list-style-type: none"> • Zone Controller: 10 VA • PO/PC Dampers: 3 VA • All VA specifications at 24 VAC
Fuse	5 x 20mm 30 ma Slo-Blo
Temperature Ratings	Shipping: -20° to 150° F Operating: -20° to 165° F
Humidity Ratings	5% to 95% RH non-condensing
Wiring	18-gauge SOLID wire



Supply Air Sensor

ZONEBB4CN01
Zone Controller

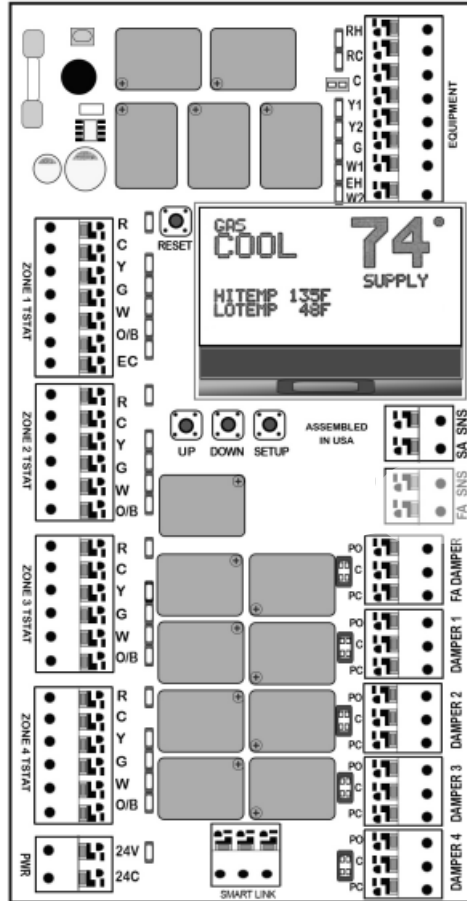

- SA SNS : Stands for Supply Air Sensor. Zone board comes with one. Needs to be connected to the side of the main duct.
- Example on the right is how it is installed in test labs



Thermostat Wiring - Up to 4 Zones

ZONEBB4CN01
Zone Controller

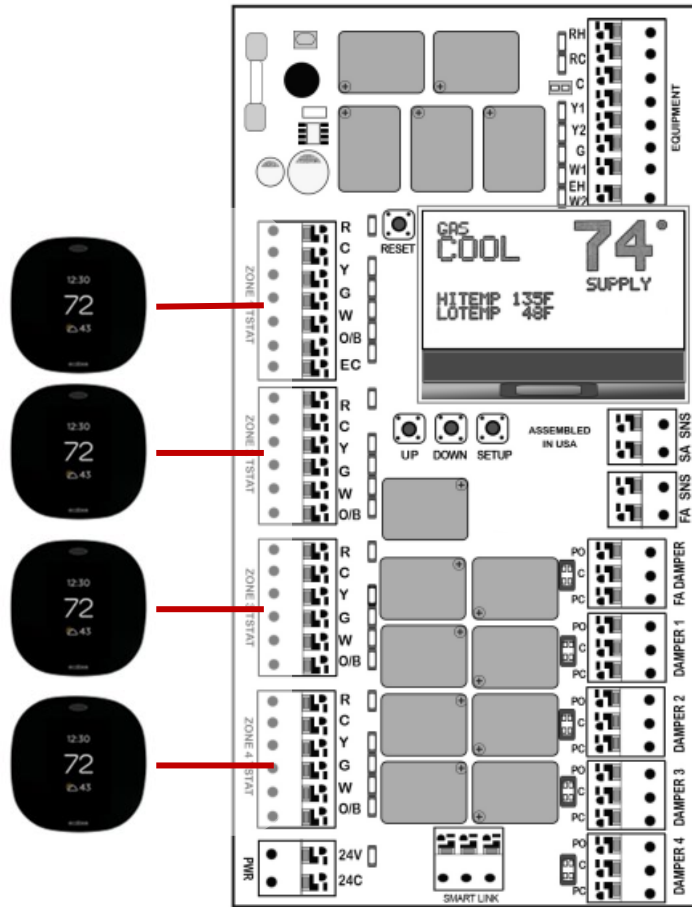

- Thermostat Wire. Depending on number of zone each zone is marked on the board. Lights on the board as well light up to tell you which wire is energized.
- Example below is how it is installed in test labs

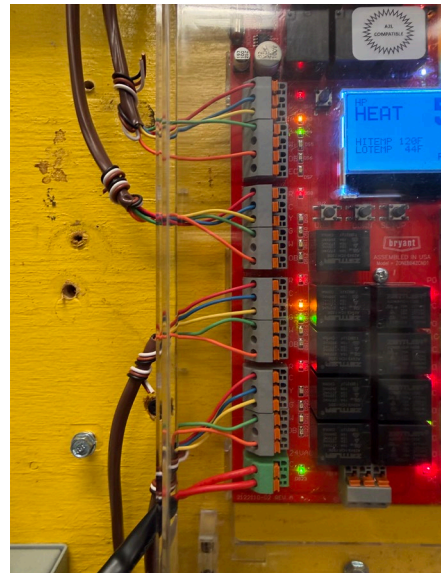

Heat Pump Thermostat



R
C
Y
G
W
O/B

Connect to matching terminals on board.

ZONEBB4CN01
Zone Controller

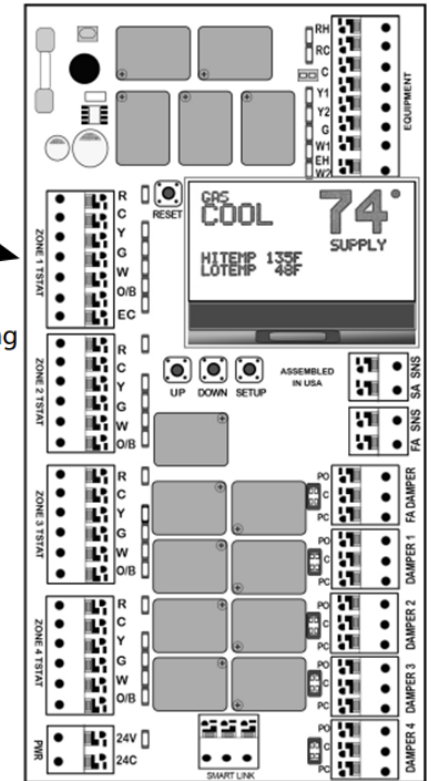

Follow Zone Dampers Installation Instructions IM-DAMP-17

ZONEBB4CN01 Zone Controller

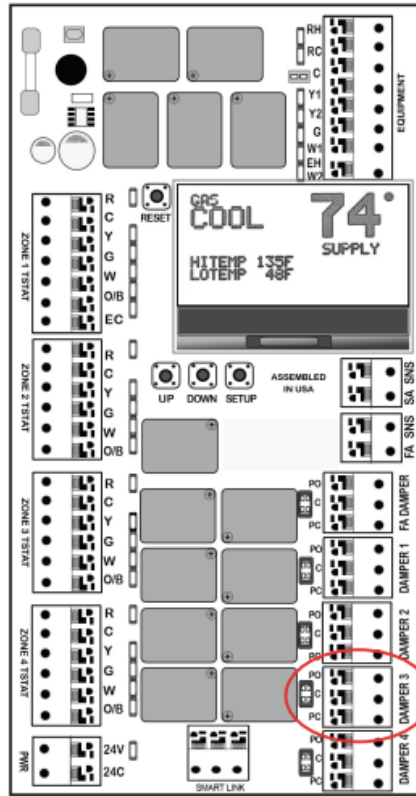

Fig. 3 – Controller Wiring

Power Open/Power Close 3-Wire Dampers

1. Use 18/3 solid core wire
2. Strip 1/2 inch of insulation from each wire.
3. Hold down the orange button on the Damper 1 terminal block and push the three wires for the zone damper into the SCREWLESS terminals. Use WHITE for Common (C), GREEN for Power Open (PO) and RED for Power Close (PC).
4. Connect the other end of the wires to the terminals on the zone damper, using the same color code.
5. Repeat steps 3 and 4 for the Zone 2 damper.

Connect 3-wire damper to FA damper.

Connect 3-wire damper to damper 1, 2, 3 and 4.

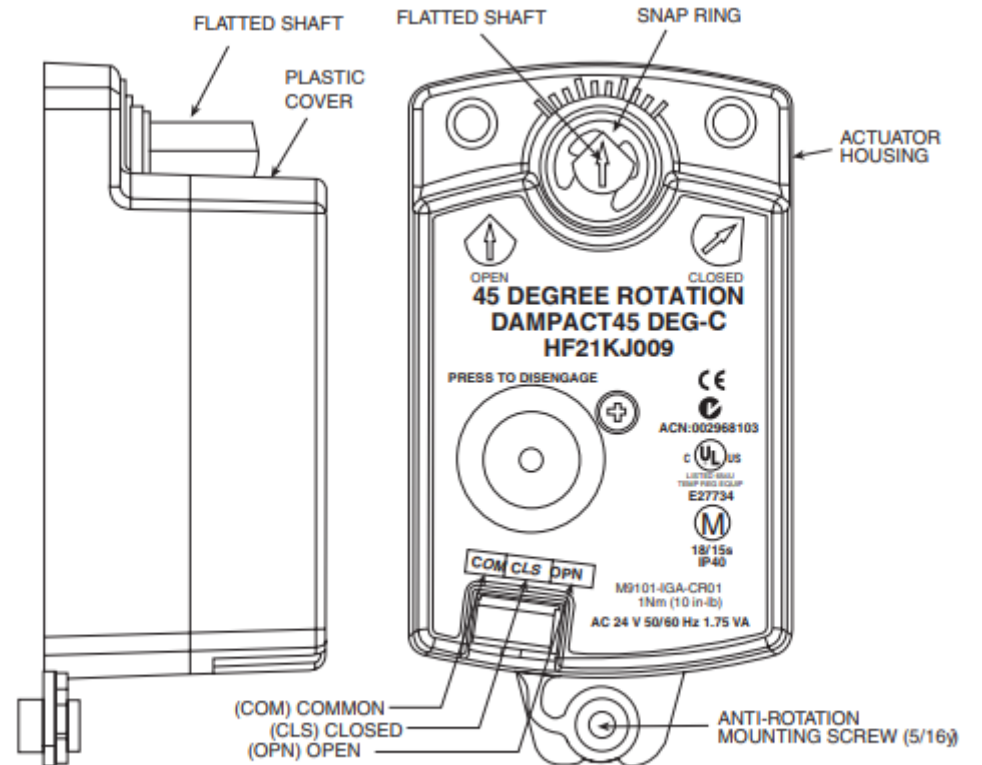
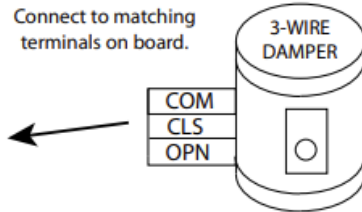

Fig. 2–Actuator Detail (45° round shown)

Barometric Damper Installation

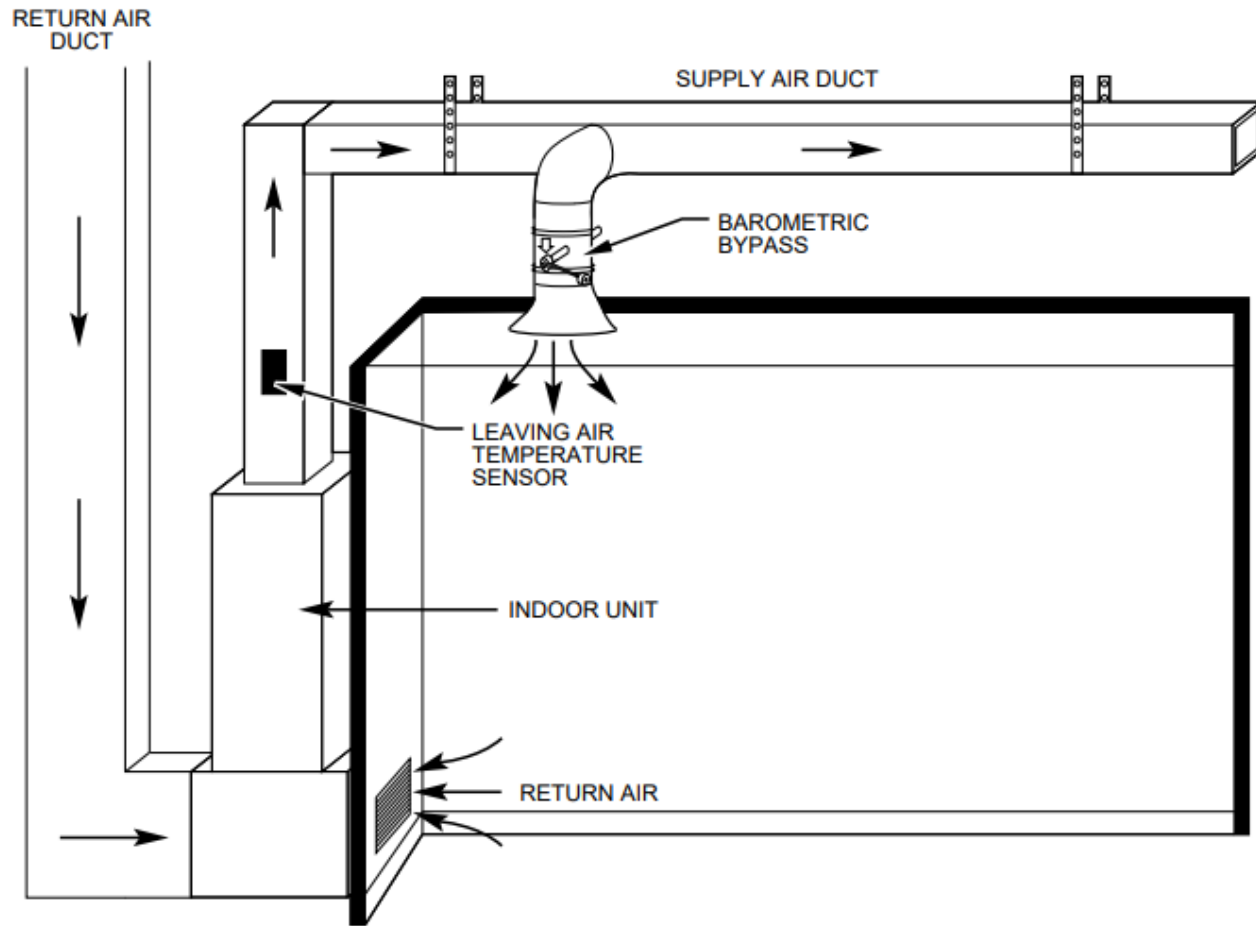

Fig. 3—Dump Zone Installation

Follow Barometric Damper
Installation Instructions
Ej: [IM-DAMP-08](#)

Use Dump Zone
Installation
Method





DRIVING CHANGE

Crossover ODU / Res Fan Coil Phase 1

RES Crossover Zoning – List of Equipment



Zoning Controller

- ZONEBB4ZCN01 – Preferred™ Four-Zone System



24V Thermostat

- EB-STATE3LTIBR-01 – ecobee Smart Thermostat



Dampers

- DAMPRND06INC – Zone Dampers
- DAMPBAR10INC – Bypass Barometric Damper

Notes:

-Testing was conducted with damper noted above; additional damper options are available for use with Crossover zoning. ([Damper Product Data](#))

-Any compatible heat pump thermostat will work for zoning application

Compatible Bryant Air Handlers

Bryant Air Handlers*	Model Family	Cooling Stages	Motor
Preferred (Mid)	FT5	2	VS ECM
Legacy (Entry)	FJ5	1	MS ECM
	FMA5X	1	MS ECM
	F55	2	MS ECM
Multi-Family	FMU(C)5Z	1	MS ECM
	FMU(C)5X	1	PSC
	FMA5L	1	PSC
Builder	FG5	2	VS ECM

*Refer to AHRI for complete list of compatible indoor units.

Note:
All wiring diagrams based on FT5. Bryant Crossover zoning is compatible with any rated fan coil.

RES Crossover Zoning Schematic



37MURAQ/HAQ
Outdoor Unit



24V
Communication



Fan Coil
Indoor Unit

Reference installation manual for
Fan coil and 37MURA/37MUHA for wiring
schematics

ZONEBB4CN01
Zone Controller

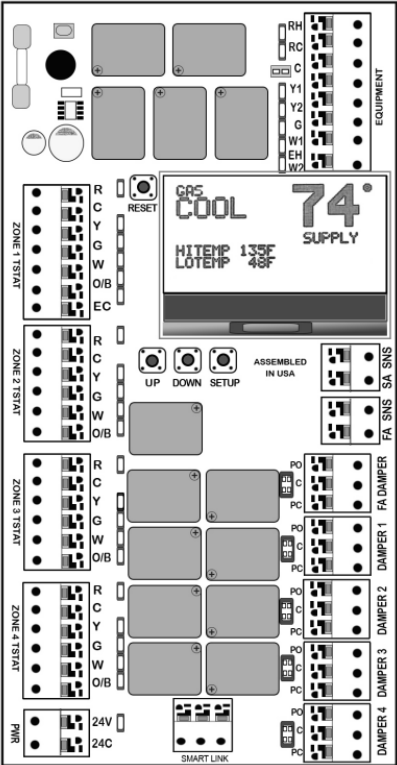

24V Connection from Zoning Controller to Air Handler
18-gauge solid thermostat wire

ZONEBB4CN01
Zone Controller

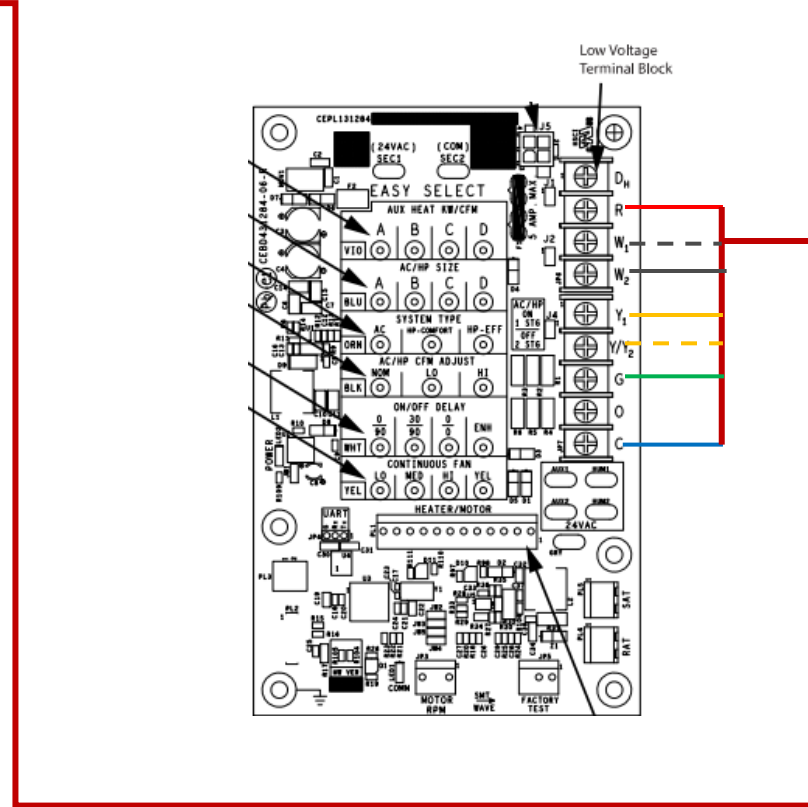
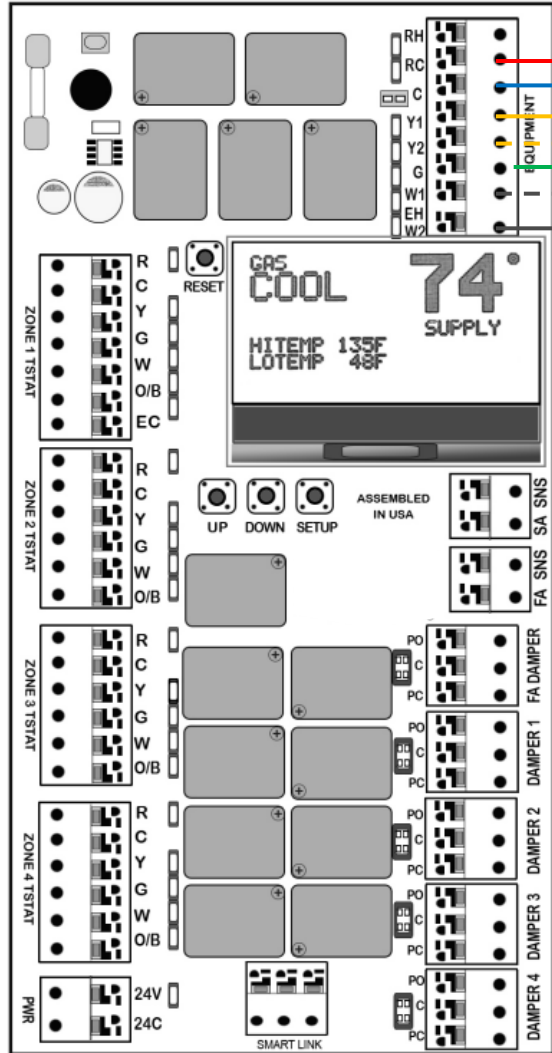

Wiring diagram shown is
Residential FT5 Air Handler



Outdoor Wiring

24V Connection from residential air handler to Crossover

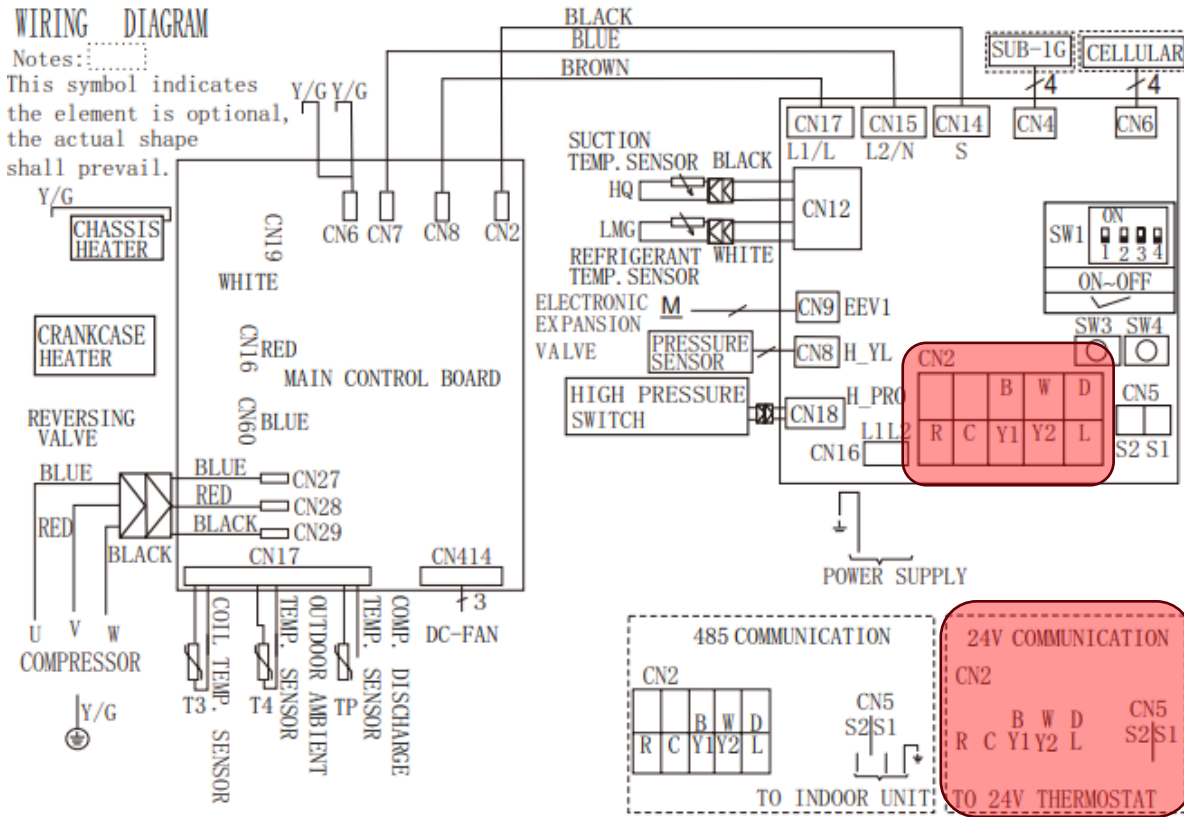

Leak Sensor Trip Wiring

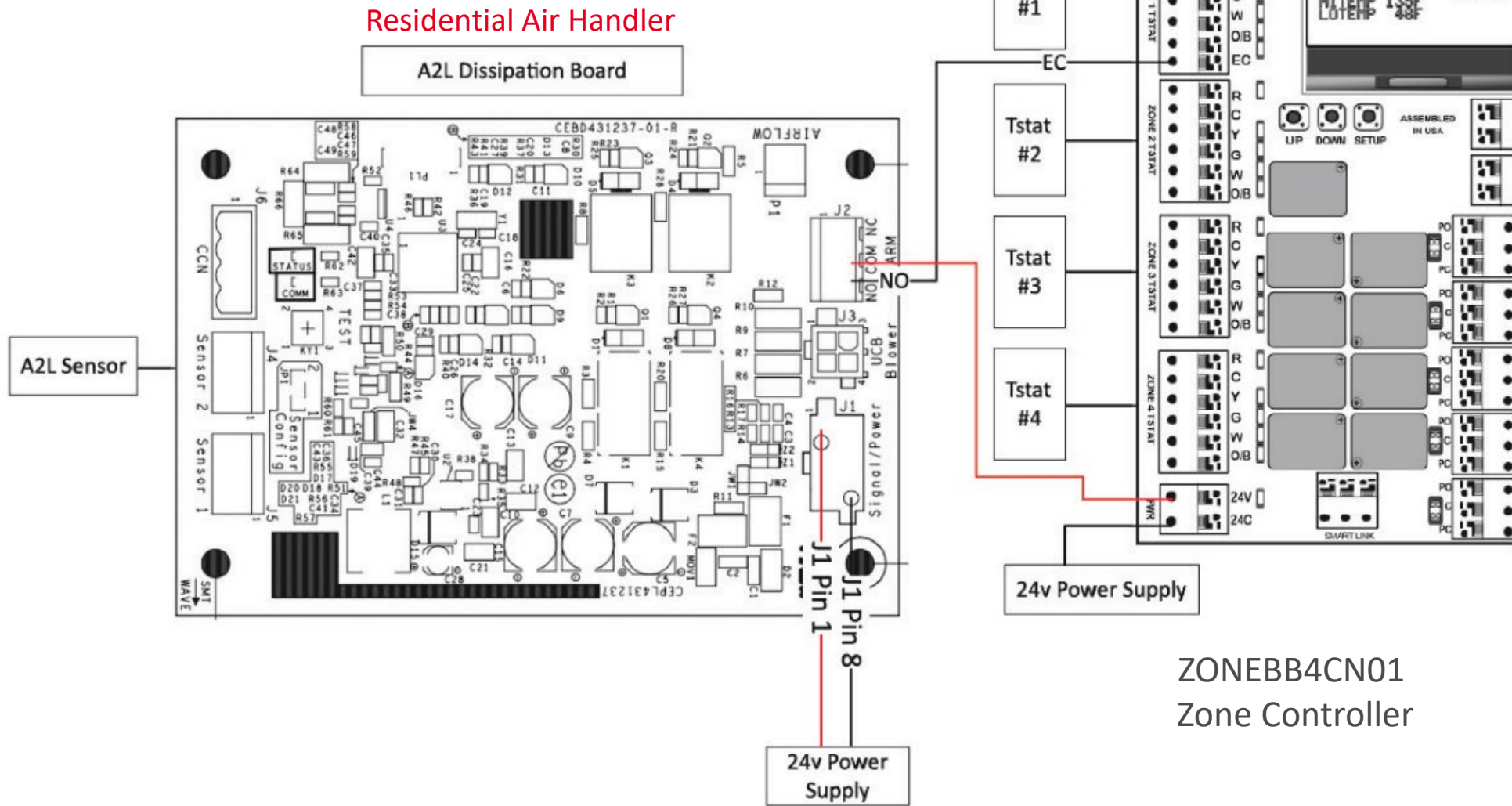

Fig. 3 – Dissipation Control Wiring



DRIVING CHANGE

Crossover ODU w/ 45MUA(H)A Phase 2



Zoning Controller

- ZONEBB4ZCN01 – Preferred™ Four-Zone System



24V Thermostat

- EB-STATE3LTIBB-01 – ecobee Smart Thermostat



Dampers

- DAMPRND06INC – Zone Dampers
- DAMPBAR12INC – Bypass Barometric Damper

Notes:

-Testing was conducted with damper noted above; additional damper options are available for use with Crossover zoning. ([Damper Product Data](#))

-Any compatible heat pump thermostat will work for zoning application

Indoor AHUs

Legacy™ Crossover AHU
(45MUAA)



Preferred™
Crossover AHU
(45MUHA)



Crossover Zoning Schematic Scenario 1

ZONEBB4CN01 Zone Controller

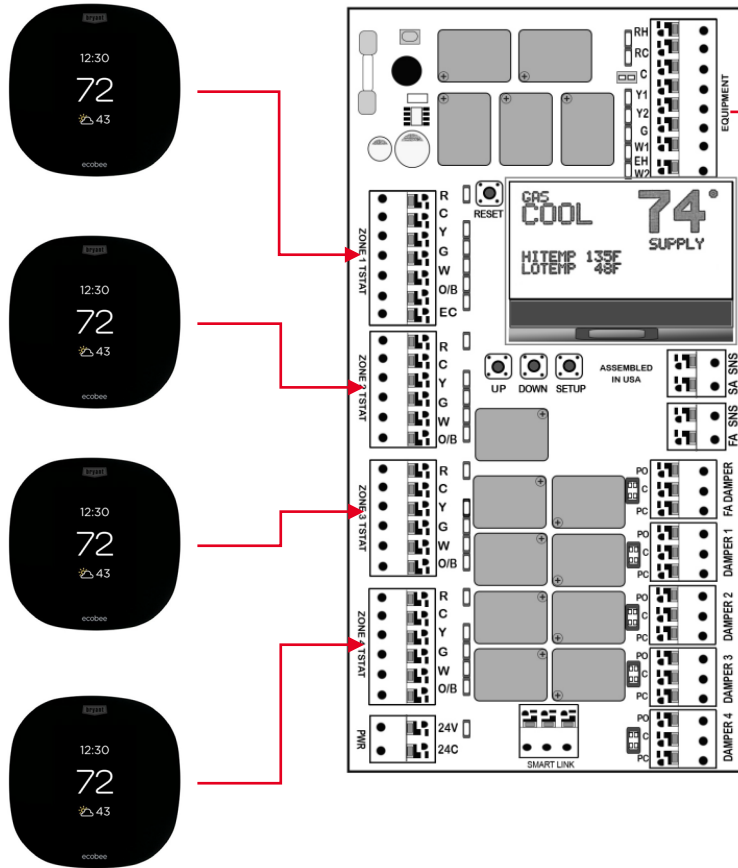

24V Thermostat
Input



S1 – S2

37MURA
37MUHA
Crossover Heat Pump



Indoor / Outdoor Wiring

ZONEBB4CN01
Zone Controller

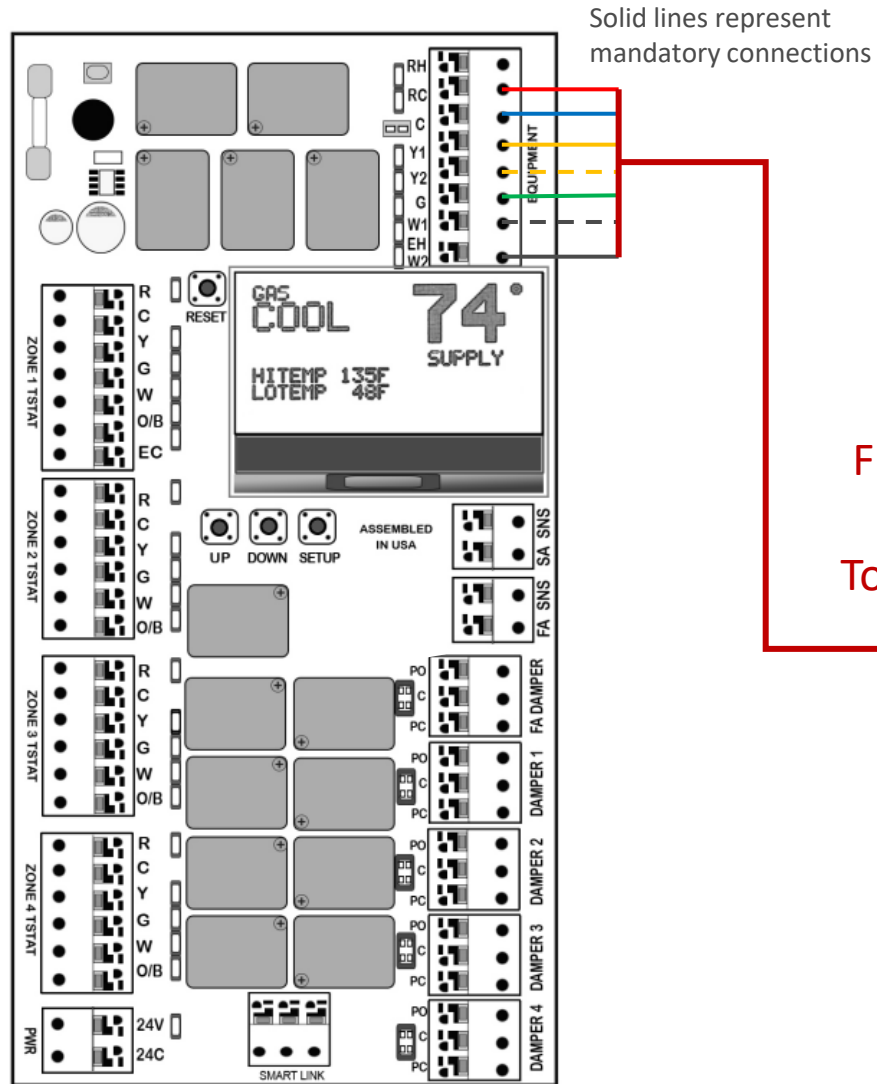

From Zoning
Controller
To Indoor Unit

- Use as reference Scenario #1 Wiring method from 45MUAA: Installation Instructions. (Fig 23 – page 24)
- S1 S2 Connection from Indoor to Outdoor

45MUAA/HA AHU Board

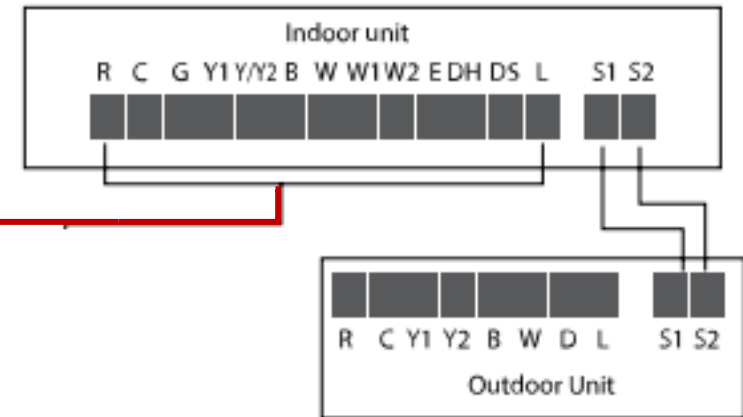

Fig. 23 — Scenario 1





DRIVING CHANGE

Back-up

Wiring Diagram

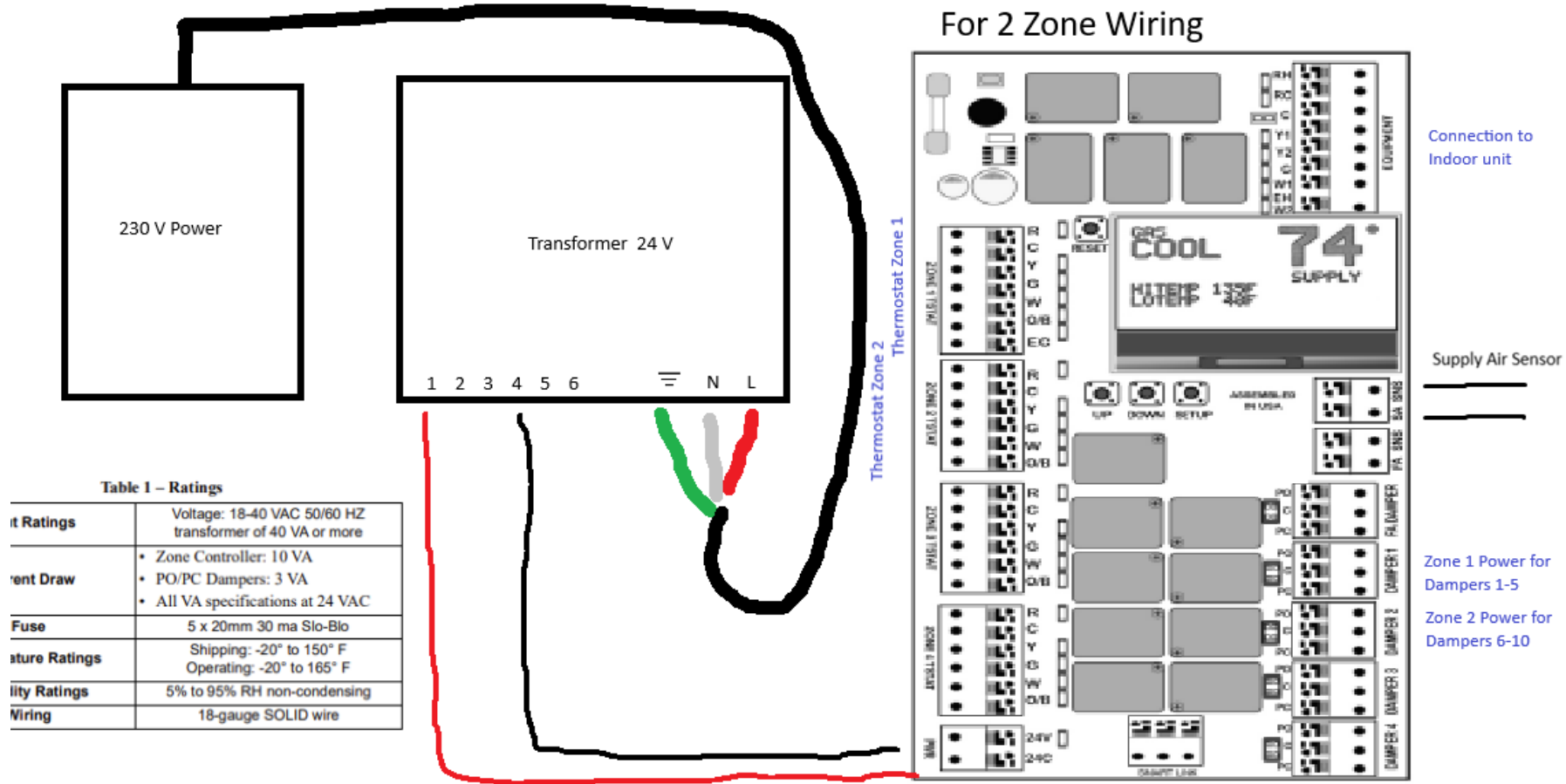

- Example for 2 Zone setup with 10 dampers.
- 5 Dampers for first zone 5 for second



Sample Ductwork (In-Lab)



Thermostat Wiring - Up to 4 Zones

ZONEBB4CN01
Zone Controller

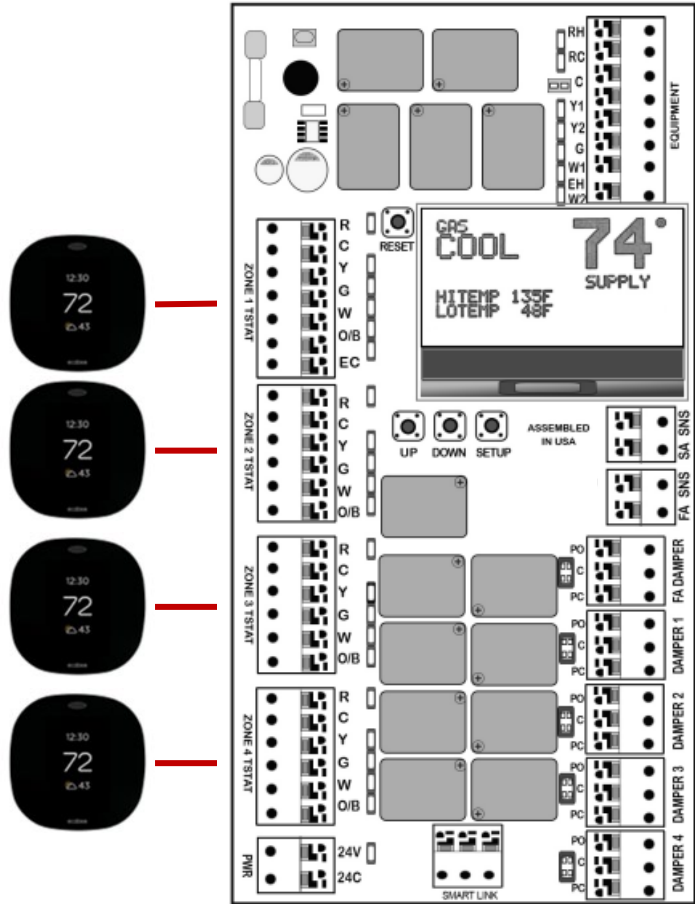

- Thermostat Wire. Depending on number of zone each zone is marked on the board. Lights on the board as well light up to tell you which wire is energized.
- Example on the right is how it is installed in Test Labs

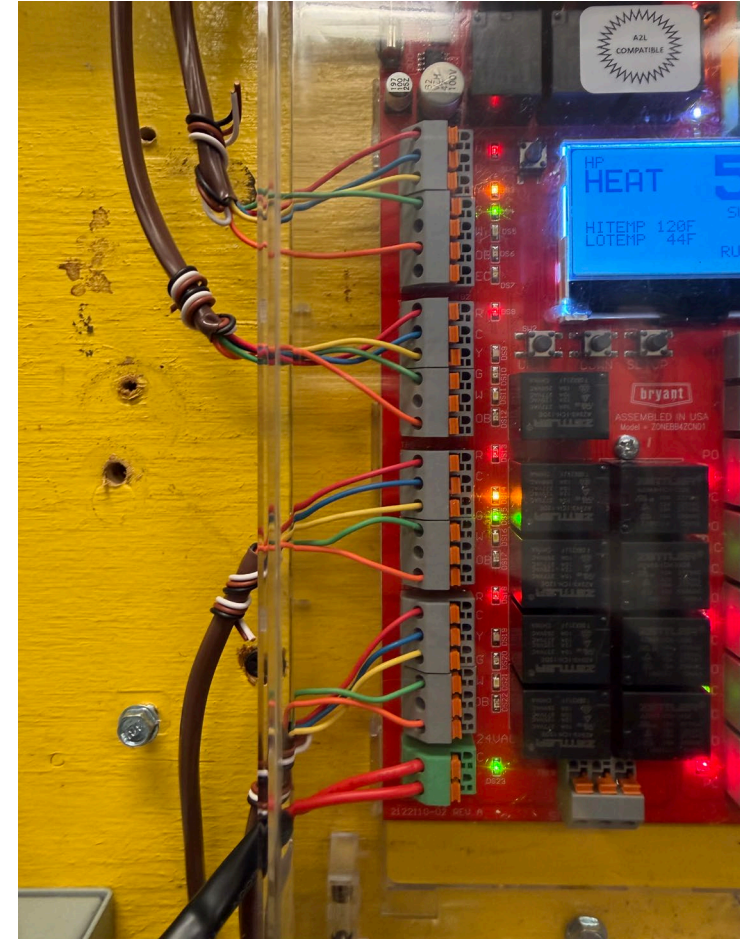

Transformer Wiring

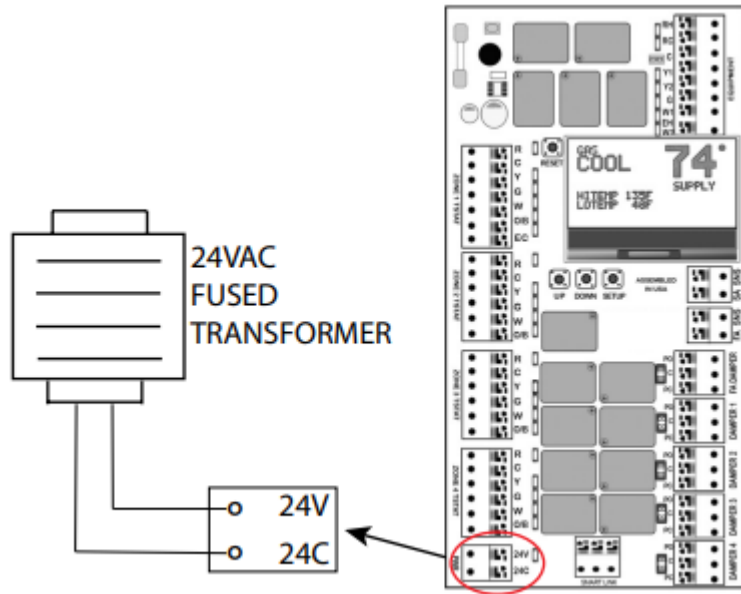

- Top 24V for Hot
- Bottom 24C Common



Damper Wiring

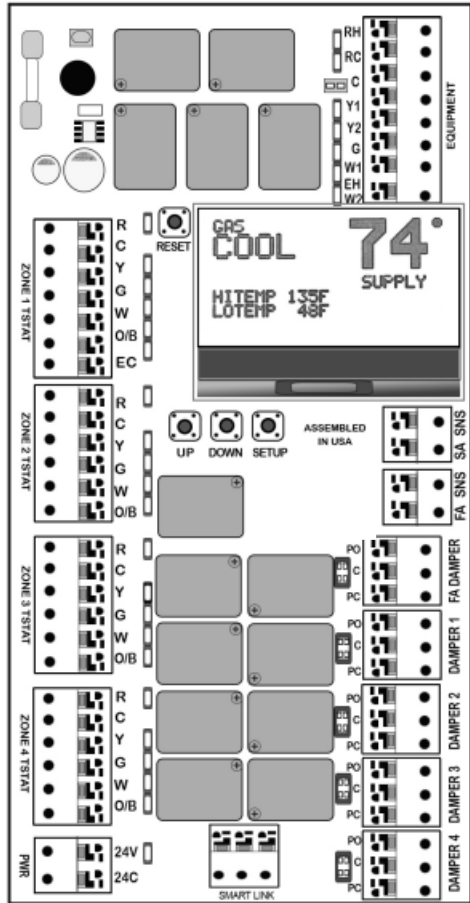
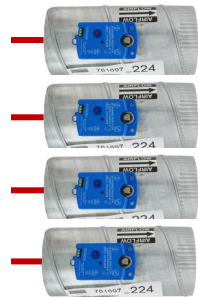
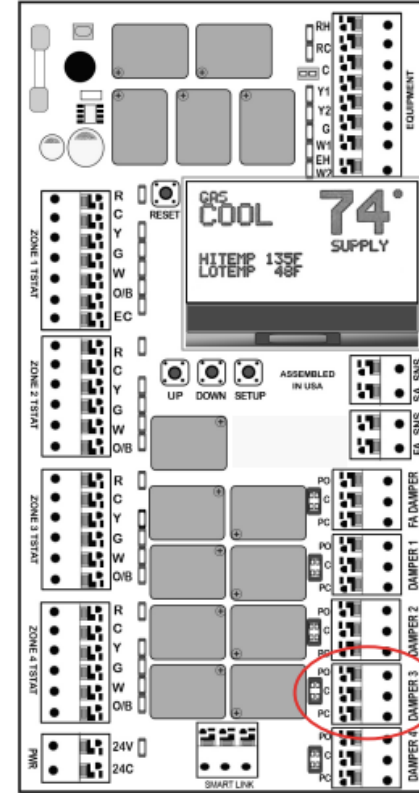

Table 1 – Ratings

Input Ratings	Voltage: 18-40 VAC 50/60 HZ transformer of 40 VA or more
Current Draw	<ul style="list-style-type: none"> • Zone Controller: 10 VA • PO/PC Dampers: 3 VA • All VA specifications at 24 VAC
Fuse	5 x 20mm 30 ma Slo-Blo
Temperature Ratings	Shipping: -20° to 150° F Operating: -20° to 165° F
Humidity Ratings	5% to 95% RH non-condensing
Wiring	18-gauge SOLID wire



- Damper requirement to use 18 gauge SOLID Wire.
- Depending on how many damper each Dampers count for 3 VA (PO/PC)
- Example on the right



Connect 3-wire damper to FA damper.

Connect 3-wire damper to damper 1, 2, 3 and 4.

Connect to matching terminals on board.

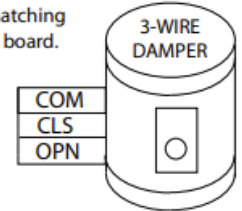
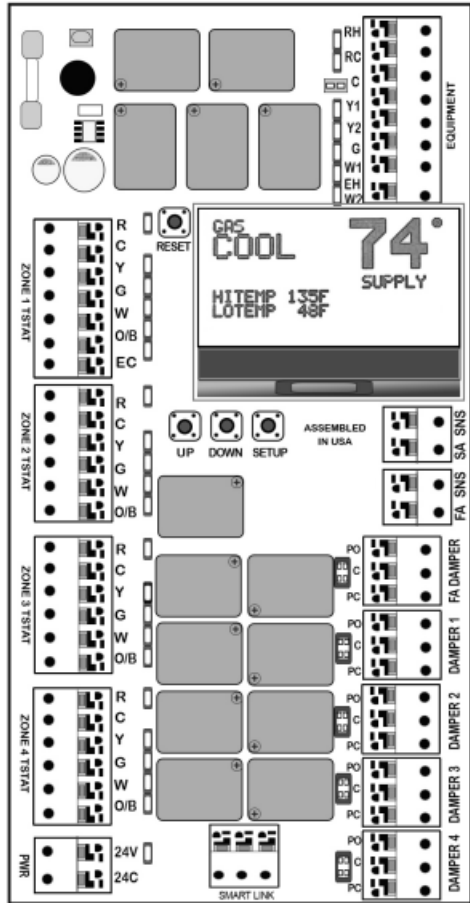

Fig. 3 – Controller Wiring



Damper Wiring



- Damper requirement to use 18 gauge SOLID Wire.
- Depending on how many damper each Dampers count for 3 VA (PO/PC)
- Example on the right

Table 1 – Ratings

Input Ratings	Voltage: 18-40 VAC 50/60 HZ transformer of 40 VA or more
Current Draw	<ul style="list-style-type: none"> • Zone Controller: 10 VA • PO/PC Dampers: 3 VA • All VA specifications at 24 VAC
Fuse	5 x 20mm 30 ma Slo-Blo
Temperature Ratings	Shipping: -20° to 150° F Operating: -20° to 165° F
Humidity Ratings	5% to 95% RH non-condensing
Wiring	18-gauge SOLID wire

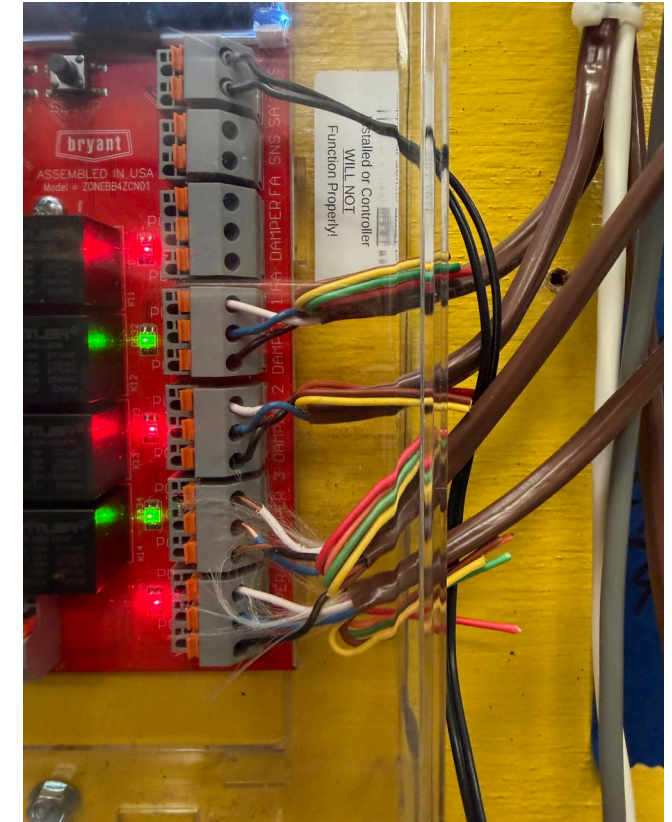

Proper System Design

Oversized systems or poorly balanced loads can lead to comfort complaints and equipment inefficiency.

Consider:

- Ensure room-by-room loads are used to calculate system sizing
- Evaluate south-facing rooms, basements, upper floors, and open-floor plans
- Match zone capacities to system minimum/maximum output to avoid short cycling

Airflow Management

High static pressure can result in unnecessary equipment wear and noise.

Consider:

- Crossover zoning requires a “dump zone” installation
- Design ducts to handle airflow when the minimum number of zones are calling
 - Low Pressure Systems < .3 in. WC
 - Med. Pressure Systems .3-.6 in. WC
 - High Pressure Systems .6-1.0 in. WC

Controls Strategy

Reduce call backs with a well-designed controls and damper configuration

Consider:

- Occupancy patterns: bedrooms and living spaces can often be separated, where infrequently utilized rooms can be placed on independent schedules
- Balance the dampers and adjust control settings as needed for optimal comfort and performance.

