

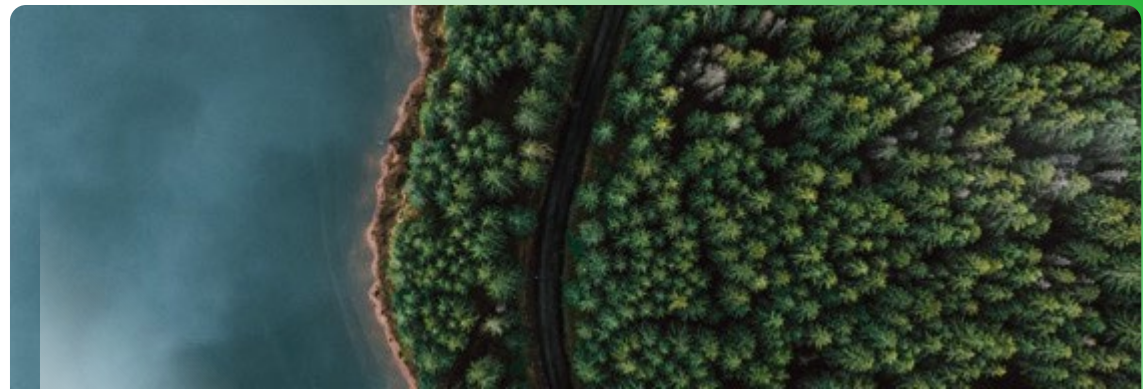

# Crossover Zoning Wiring Instructions

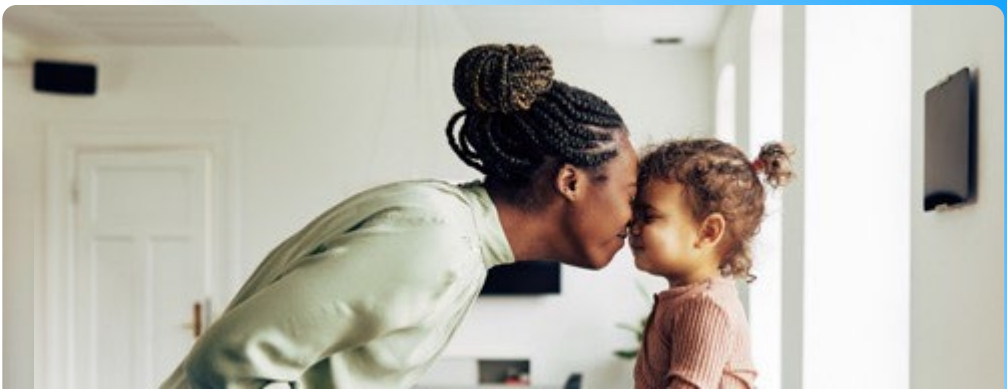

# Summary



## System Overview

- Zone Board (ZONECC4CN01)
  - Powering Zone Board
- Supply Air Sensor
- Thermostat Wiring
- Dump Zone

## Phase Updates

- Equipment used in lab testing
- System Wiring
  - Indoor Unit Wiring
  - Outdoor Unit Wiring

# Carrier Performance™ Four-Zone Board

Control boards are the “brains” of the zoning system – they receive heat or cool calls from the thermostat, then turn on the HVAC system and controls the dampers so that only the appropriate zone gets heated or cooled

ZONECC4CN01  
(four zone)

Connectors  
from  
Thermostats

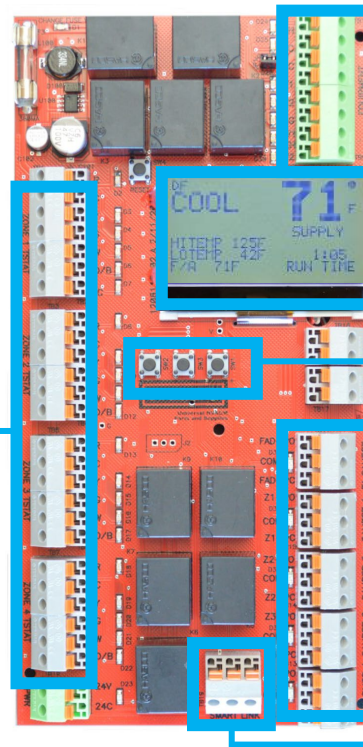

Connector to  
HVAC

Display  
Screen

Pushbutton  
Controls

Connectors to Dampers

Expansion connector (connect  
more boards for more zones)

# Wiring Diagram – Power Zoning Controller

## ZONECC4CN01 Zone Controller

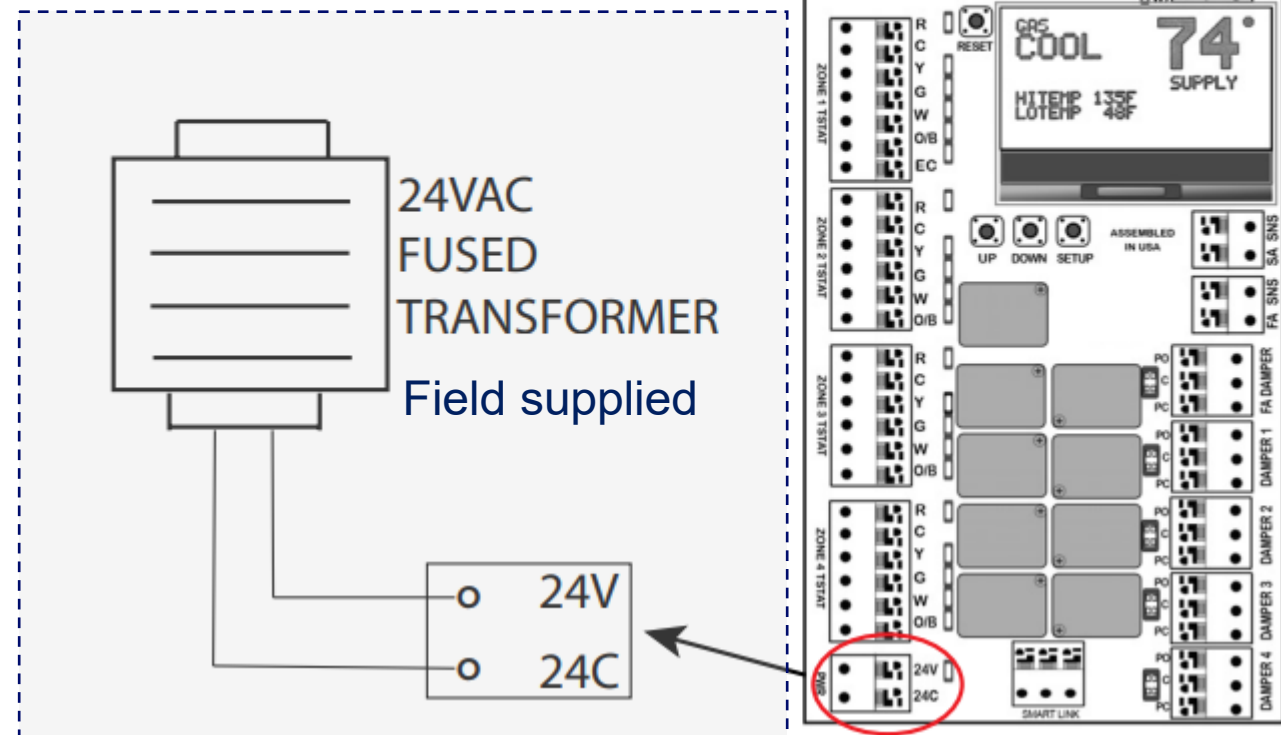

## Follow Zone Controller Installation Instructions

Table 1 – Ratings

<b>Input Ratings</b>	Voltage: 18-40 VAC 50/60 HZ transformer of 40 VA or more
<b>Current Draw</b>	<ul style="list-style-type: none"> <li>• Zone Controller: 10 VA</li> <li>• PO/PC Dampers: 3 VA</li> <li>• All VA specifications at 24 VAC</li> </ul>
<b>Fuse</b>	5 x 20mm 30 ma Slo-Blo
<b>Temperature Ratings</b>	Shipping: -20° to 150° F Operating: -20° to 165° F
<b>Humidity Ratings</b>	5% to 95% RH non-condensing
<b>Wiring</b>	18-gauge SOLID wire

# Supply Air Sensor

## ZONECC4CN01 Zone Controller

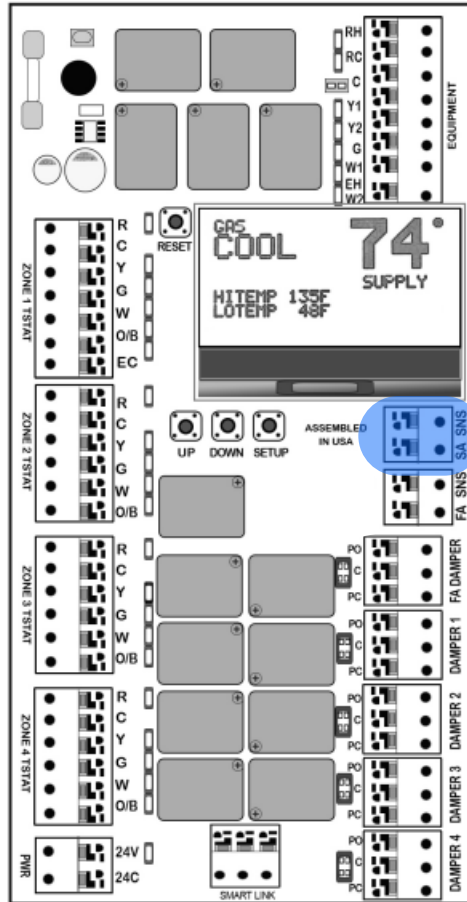

- SA SNS : Stands for Supply Air Sensor. Zone board comes with one. Needs to be connected to the side of the main duct.
- Example on the right is how it is installed in test labs

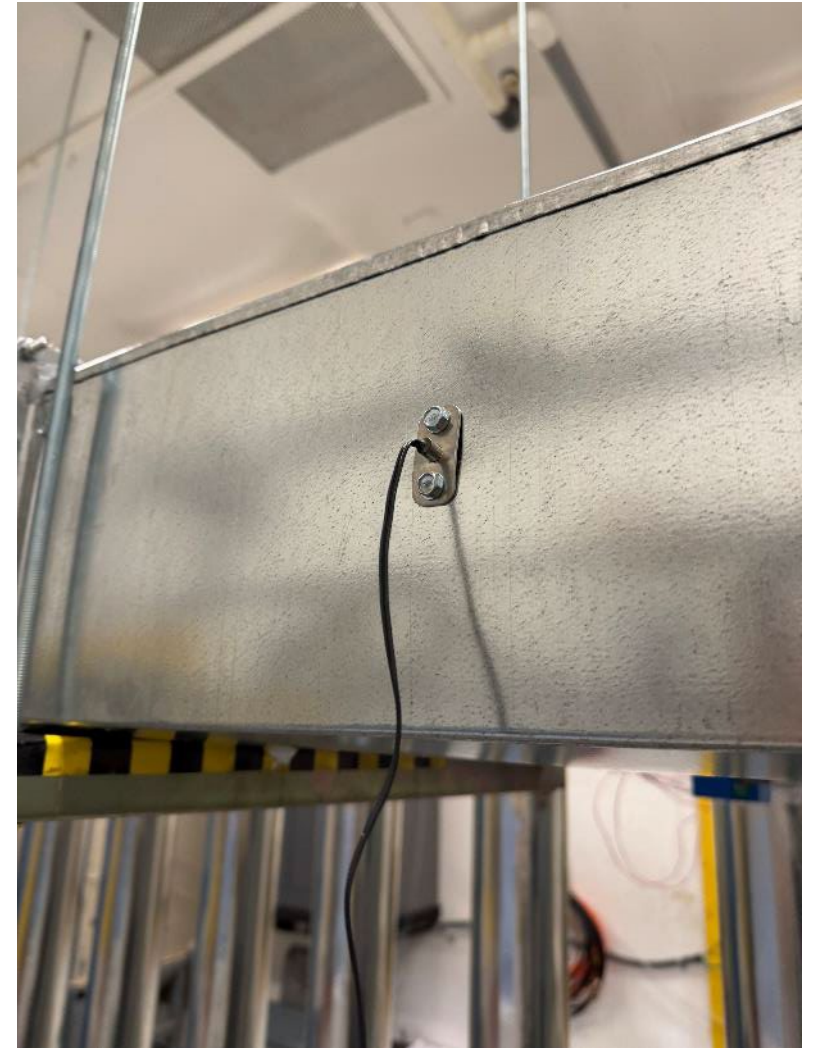

# Thermostat Wiring – Up to 4 Zones

ZONECC4CN01  
Zone Controller

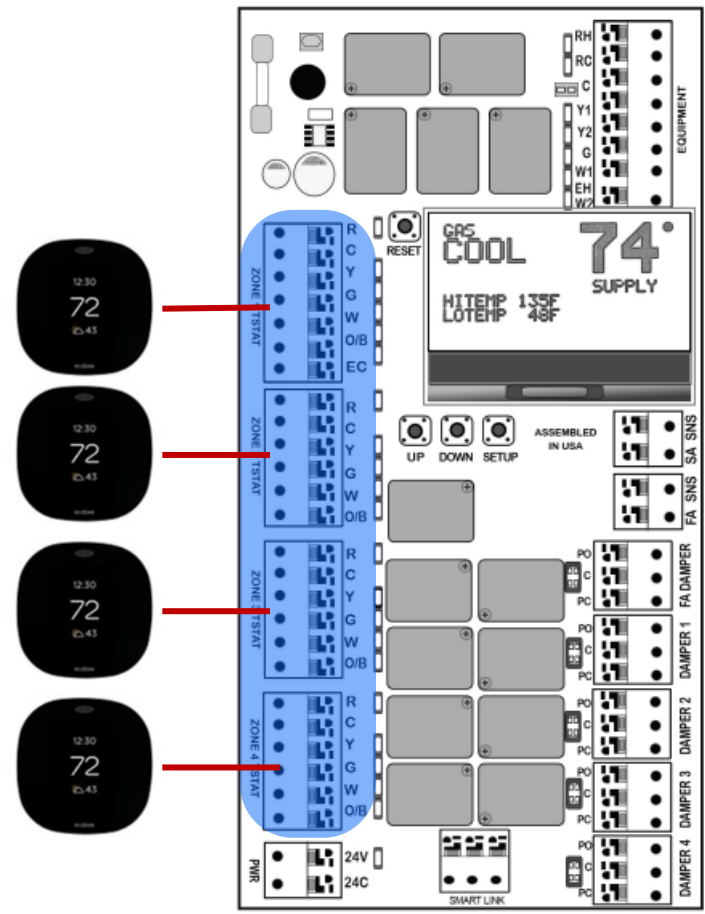

- Thermostat Wire. Depending on number of zone each zone is marked on the board. Lights on the board as well light up to tell you which wire is energized.
- Example on the right is how it is installed in test labs

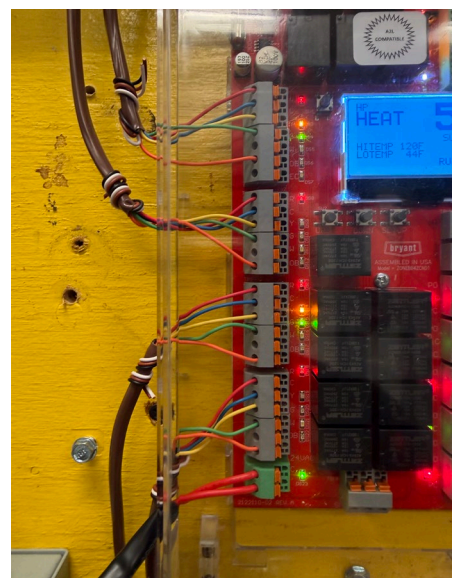

ZONECC4CN01  
Zone Controller

Heat Pump Thermostat

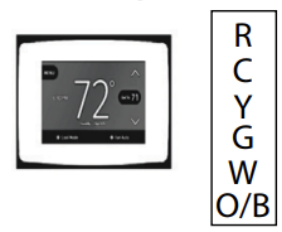

Connect to matching terminals on board.

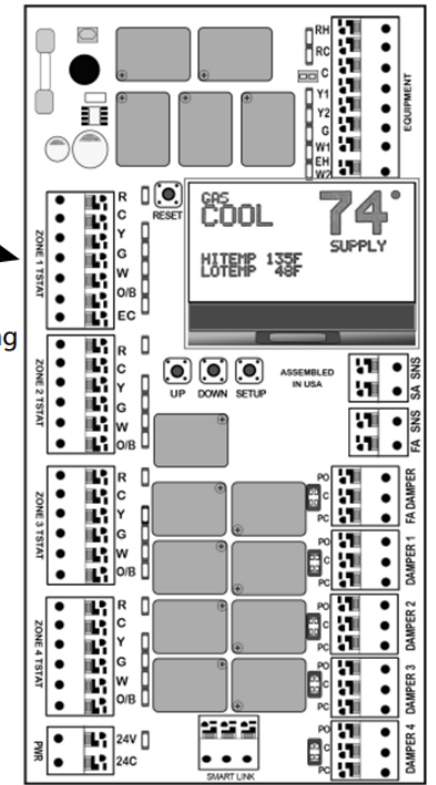

# Damper Wiring

## ZONECC4CN01 Zone Controller

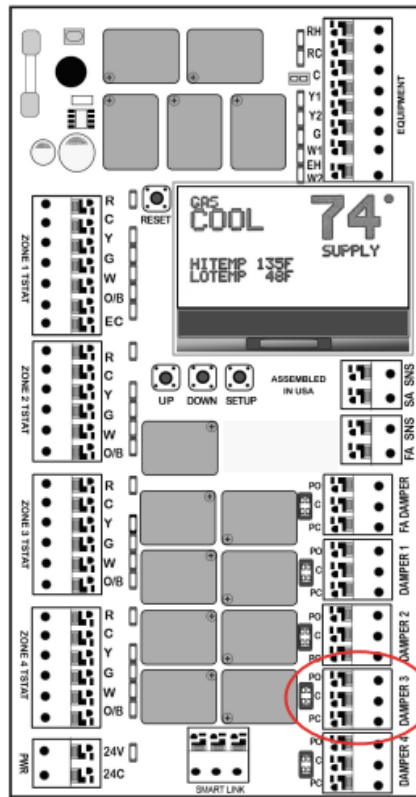

Fig. 3 – Controller Wiring

### Power Open/Power Close 3-Wire Dampers

1. Use 18/3 solid core wire
2. Strip 1/2 inch of insulation from each wire.
3. Hold down the orange button on the Damper 1 terminal block and push the three wires for the zone damper into the SCREWLESS terminals. Use WHITE for Common (C), GREEN for Power Open (PO) and RED for Power Close (PC).
4. Connect the other end of the wires to the terminals on the zone damper, using the same color code.
5. Repeat steps 3 and 4 for the Zone 2 damper.

Connect 3-wire damper to FA damper.

Connect 3-wire damper to damper 1, 2, 3 and 4.

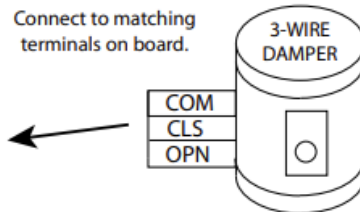

## Follow Zone Dampers Installation Instructions [IM-DAMP-17](#)

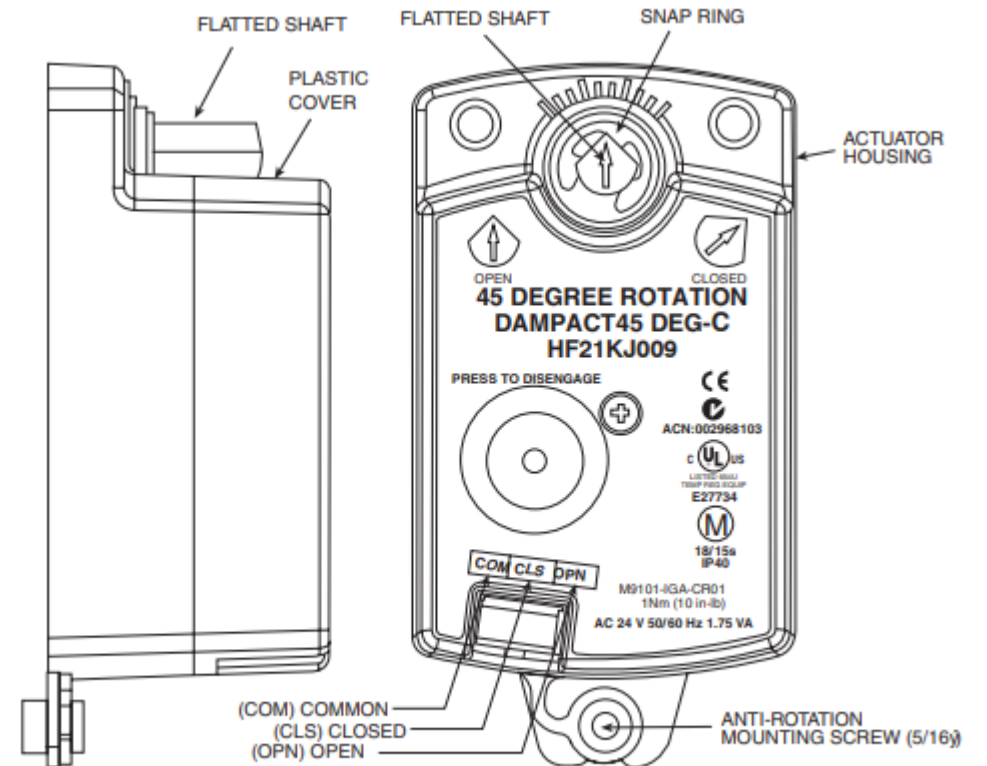

Fig. 2-Actuator Detail (45° round shown)

# Barometric Damper Installation

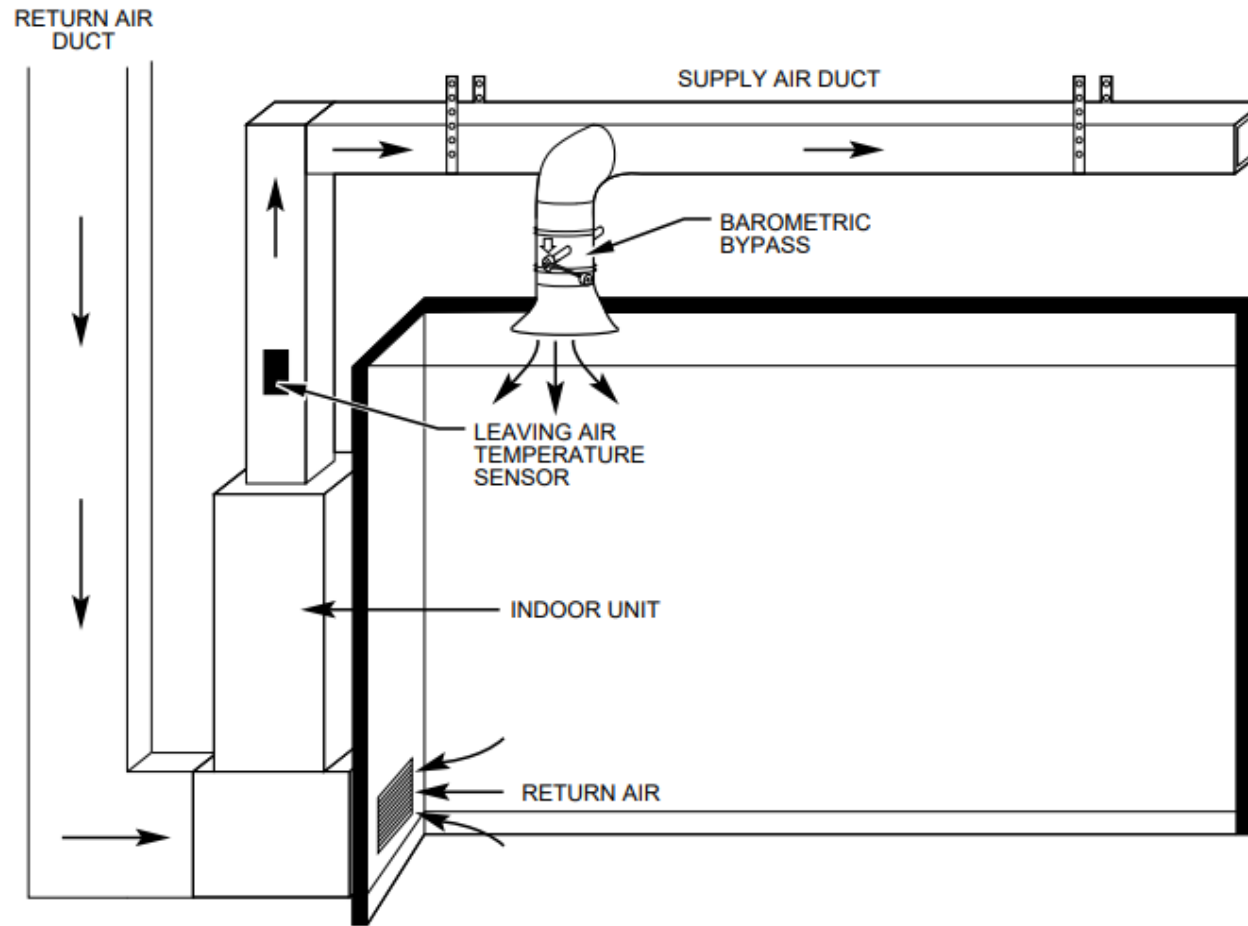

Fig. 3—Dump Zone Installation

Follow Barometric Damper  
Installation Instructions  
Ej: [IM-DAMP-08](#)

Use Dump Zone  
Installation  
Method

# Crossover ODU / Res Fan Coil Phase 1

# RES Fan Coil Crossover Zoning

## List of equipment used in testing



### Zoning Controller

- ZONECC4ZCN01 – Performance™ Four-Zone System



### 24V Thermostat

- EB-STATE3LTICB-01 – ecobee Smart Thermostat



### Dampers

- DAMPRND06INC – Zone Dampers
- DAMPBAR10INC – Bypass Barometric Damper:

### Notes:

-Testing was conducted with damper noted above; additional damper options are available for use with Crossover zoning. ([Damper Product Data](#))

-Any compatible heat pump thermostat will work for zoning application

## Compatible Carrier AHUs

Carrier Fan Coils*	Model Family	Cooling Stages	Motor
Performance (Mid)	FT5	2	VS ECM
	FJ5	1	MS ECM
Comfort (Entry)	FMA5X	1	MS ECM
	F55	2	MS ECM
	FMU(C)5Z	1	MS ECM
Multi-Family	FMU(C)5X	1	PSC
	FMA5L	1	PSC
Builder	FG5	2	VS ECM

\*Refer to AHRI for complete list of compatible indoor units.

### Note:

All wiring diagrams based on FT5. Carrier Crossover zoning is compatible with any rated fan coil.

# RES Crossover Zoning Schematic

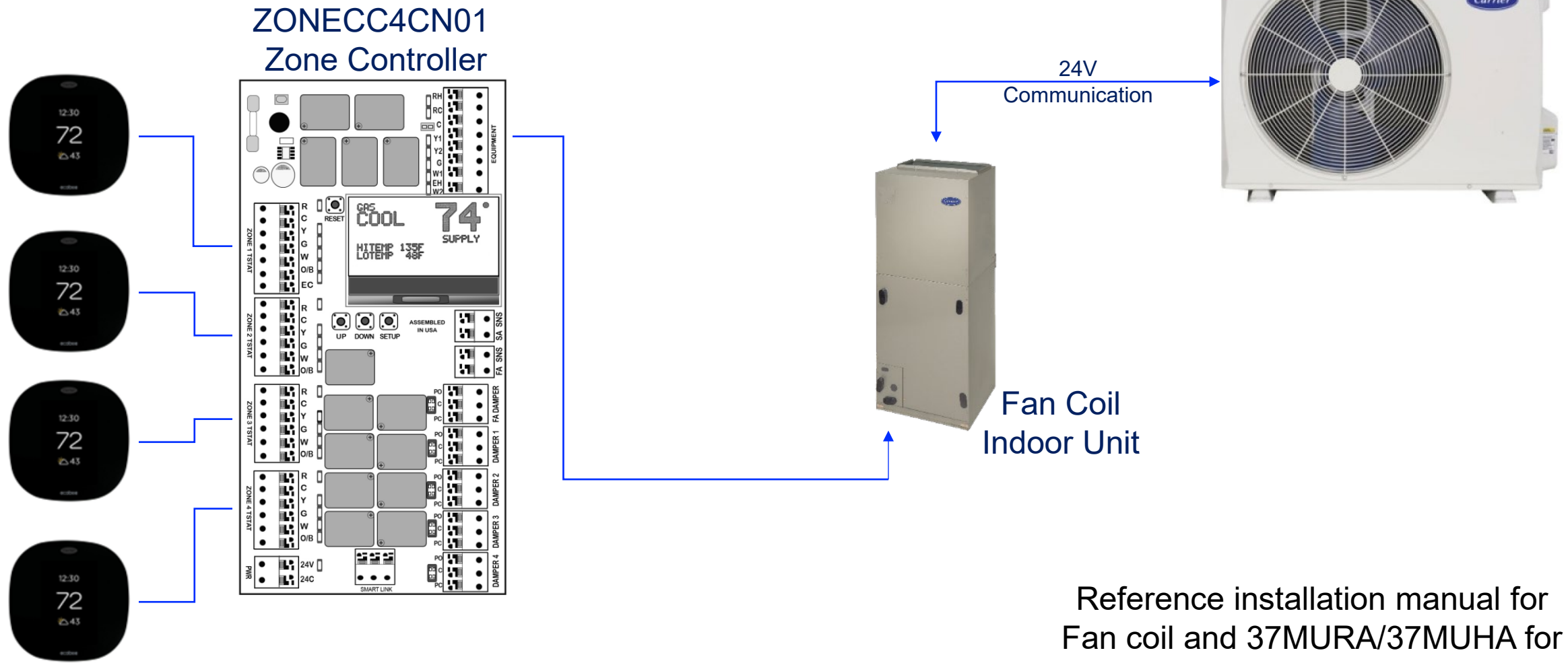

Reference installation manual for  
Fan coil and 37MURA/37MUHA for  
wiring schematics

# Indoor Wiring

## 24V Connection from Zoning Controller to Air Handler

18-gauge solid thermostat wire

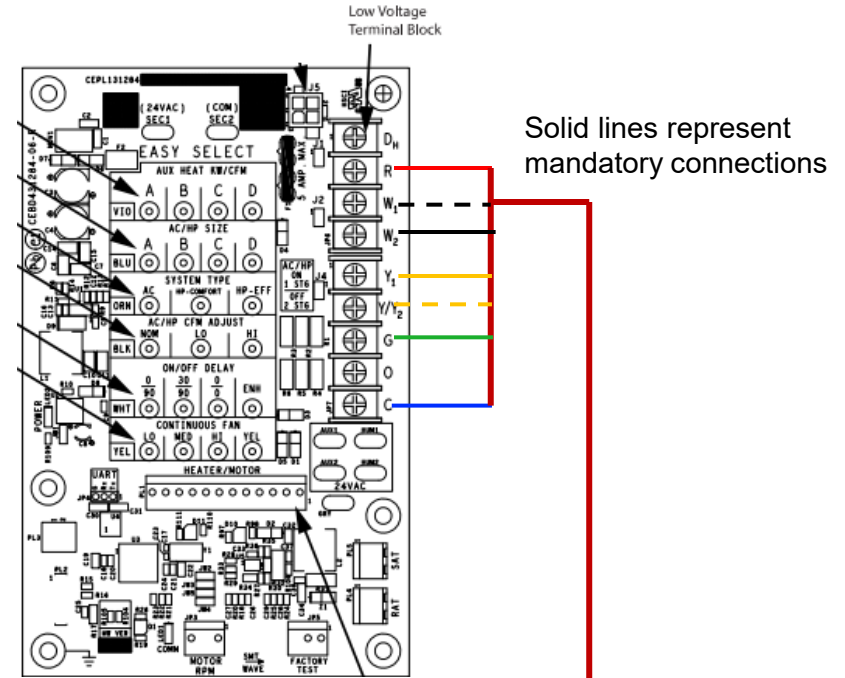
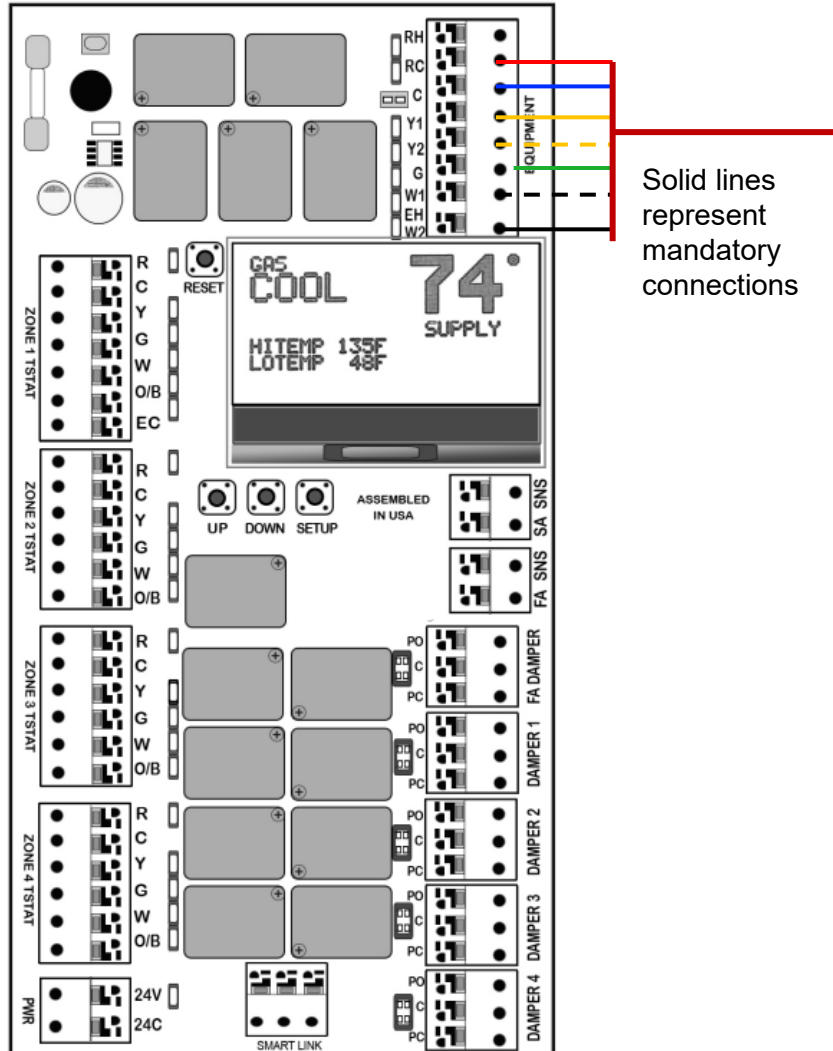

Wiring diagram shown is Residential FT5 Air Handler

# Outdoor Wiring

- 24V Connection from residential air handler to Crossover

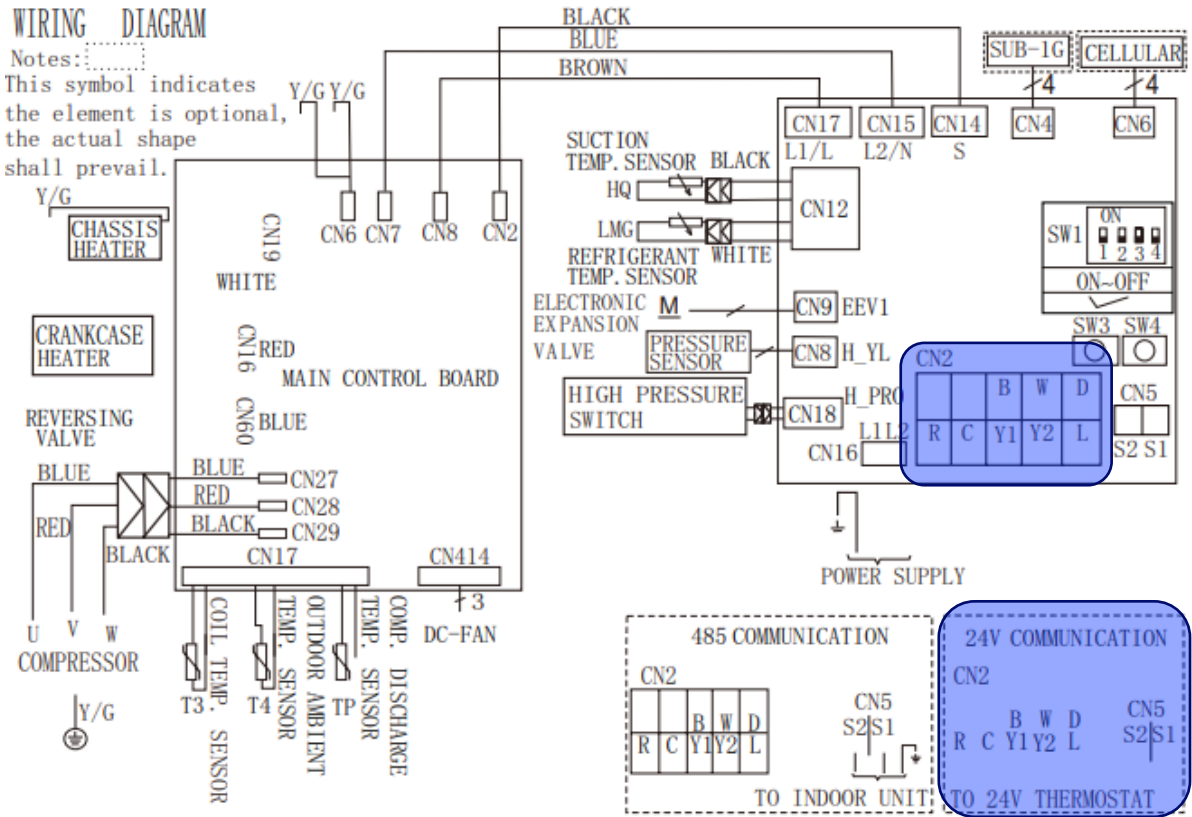

# Leak Sensor Trip Wiring

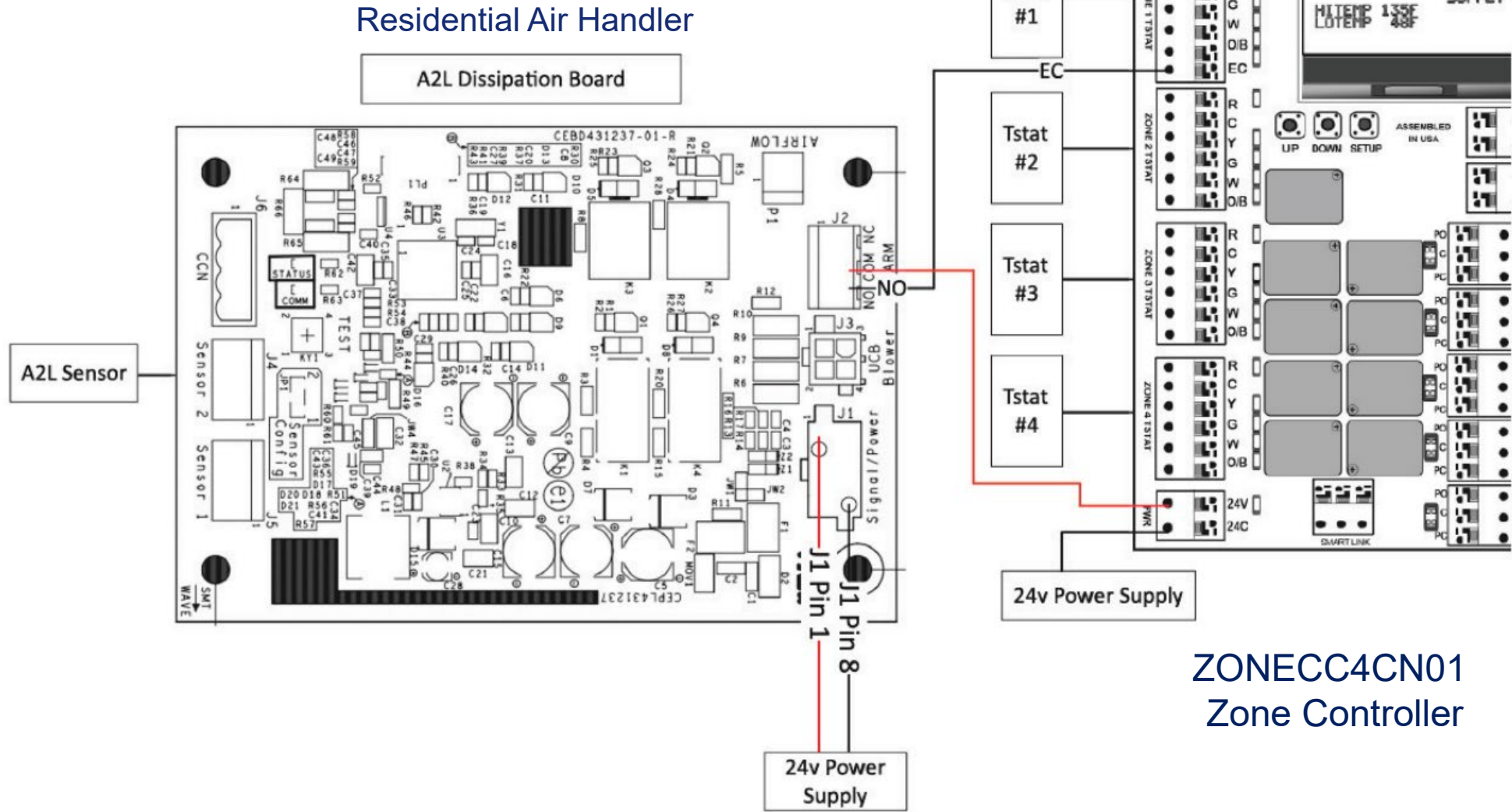

Fig. 3 – Dissipation Control Wiring

# Crossover ODU w/ 45MUA(H)A Phase 2

# Crossover Fan Coil – List of Equipment

## List of equipment used in testing



### Zoning Controller

- ZONECC4ZCN01 – Performance™ Four-Zone System



### 24V Thermostat

- EB-STATE3LTIBB-01 – ecobee Smart Thermostat



### Dampers

- DAMPRND06INC – Zone Dampers
- DAMPBAR12INC – Bypass Barometric Damper

### Notes:

-Testing was conducted with damper noted above; additional damper options are available for use with Crossover zoning. ([Damper Product Data](#))

-Any compatible heat pump thermostat will work for zoning application



Proprietary and Confidential

## Indoor AHUs

Comfort™ Crossover AHU  
(45MUAA)



Performance™ Crossover AHU  
(45MUHA)



# Crossover Zoning Schematic Scenario 1

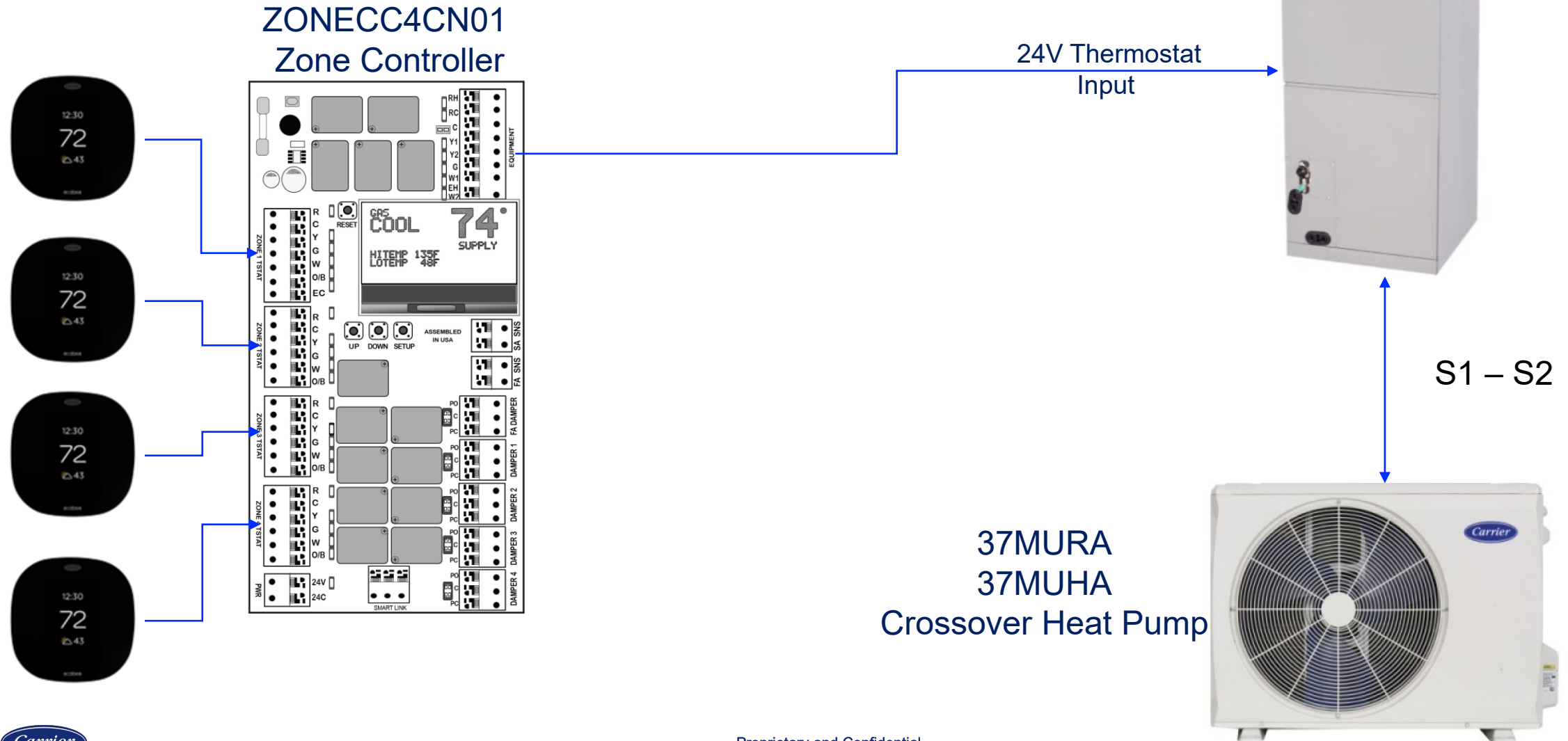

# Indoor / Outdoor Wiring

ZONECC4CN01  
Zone Controller

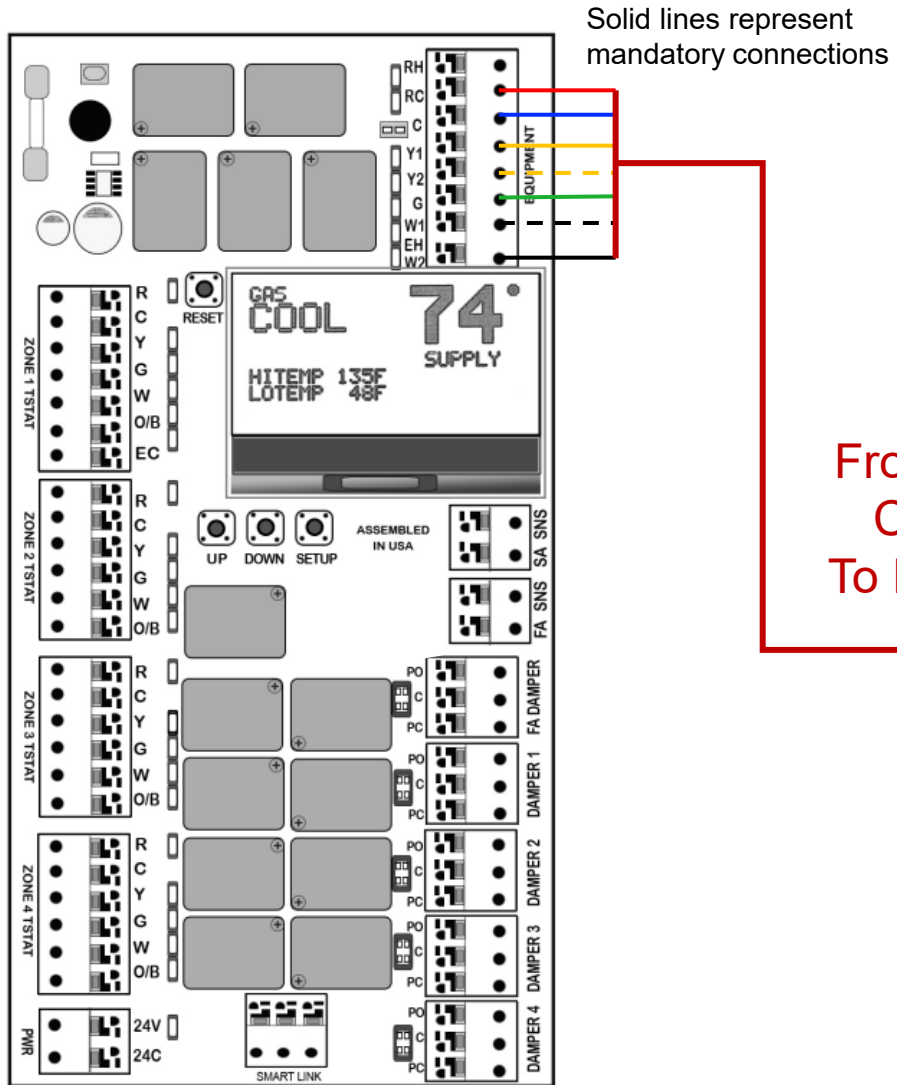

- Use as reference Scenario #1 Wiring method from 45MUA: Installation Instructions. (Fig 23 – page 24)
- S1 S2 Connection from Indoor to Outdoor

From Zoning  
Controller  
To Indoor  
Unit

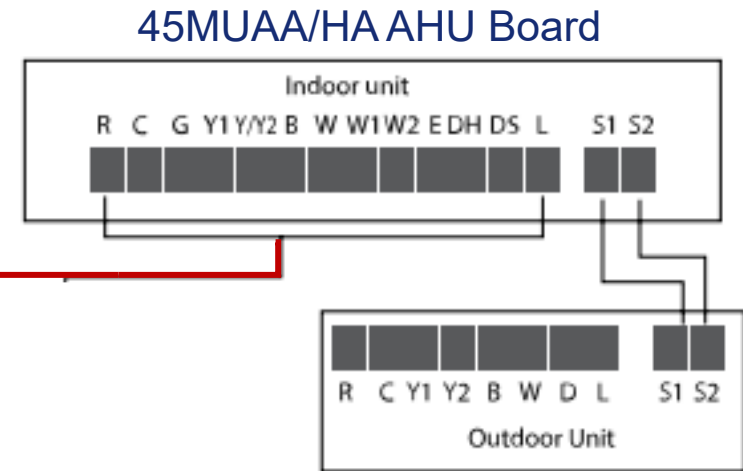
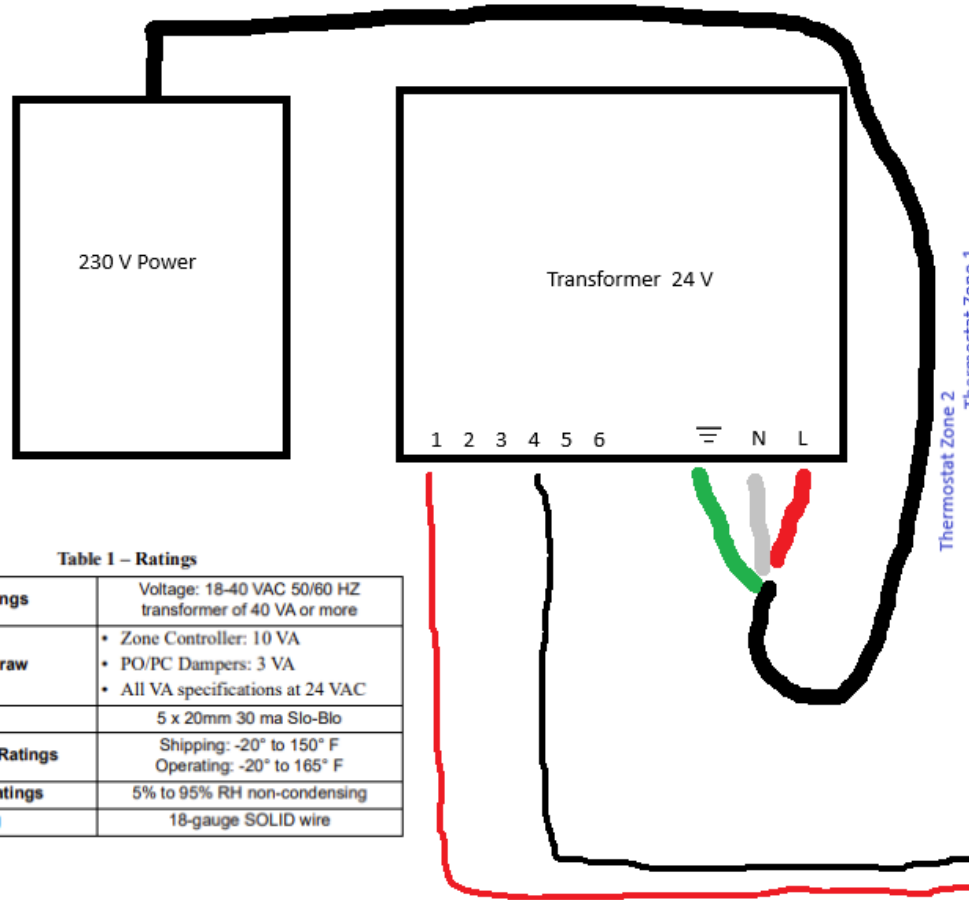

Fig. 23 — Scenario 1

# Back-up

# Wiring Diagram



**Table 1 – Ratings**

Rating	Voltage: 18-40 VAC 50/60 HZ transformer of 40 VA or more
Power Draw	<ul style="list-style-type: none"> <li>Zone Controller: 10 VA</li> <li>PO/PC Dampers: 3 VA</li> <li>All VA specifications at 24 VAC</li> </ul>
Fuse	5 x 20mm 30 ma Slo-Blo
Temperature Ratings	Shipping: -20° to 150° F Operating: -20° to 165° F
Humidity Ratings	5% to 95% RH non-condensing
Wiring	18-gauge SOLID wire

For 2 Zone Wiring

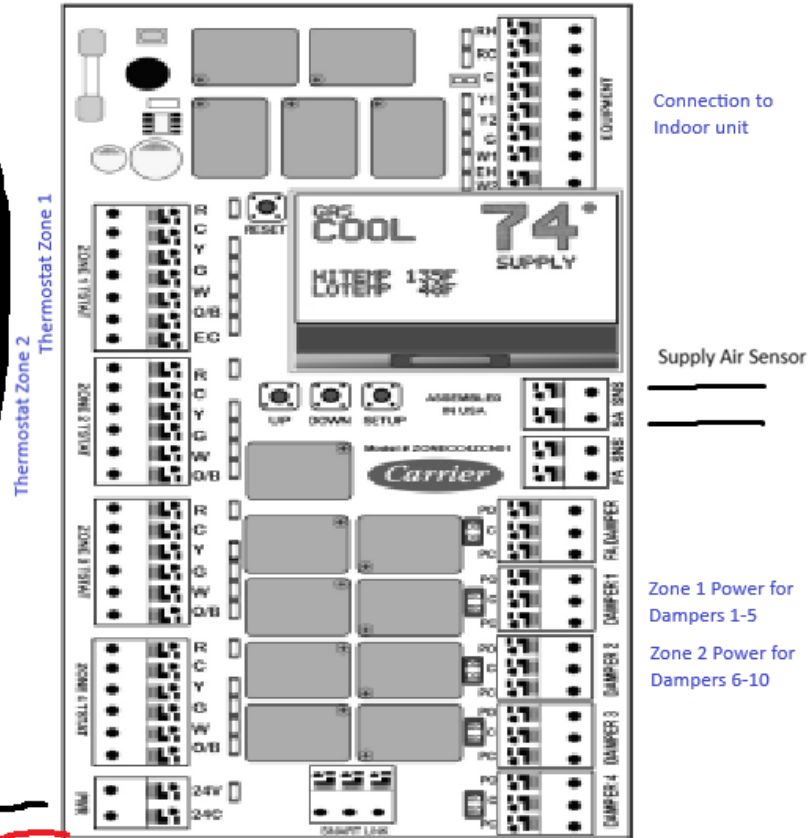

- Example for 2 Zone setup with 10 dampers.
- 5 Dampers for first zone 5 for second

# Sample Ductwork (In-Lab)



# Thermostat Wiring – Up to 4 Zones

## ZONEBB4CN01 Zone Controller

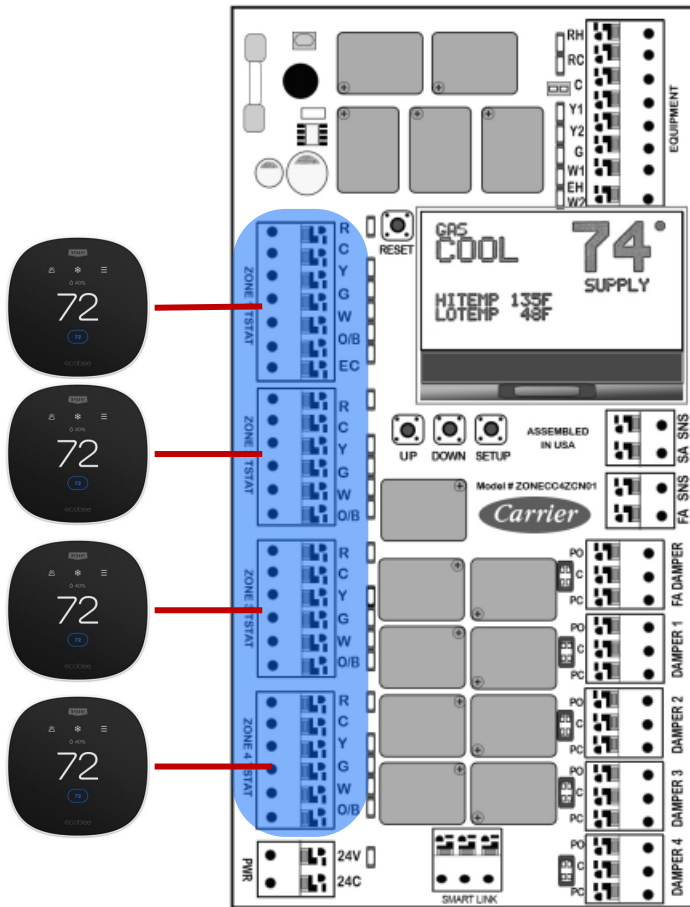

- Thermostat Wire. Depending on number of zone each zone is marked on the board. Lights on the board as well light up to tell you which wire is energized.
- Example on the right is how it is installed in Test Labs

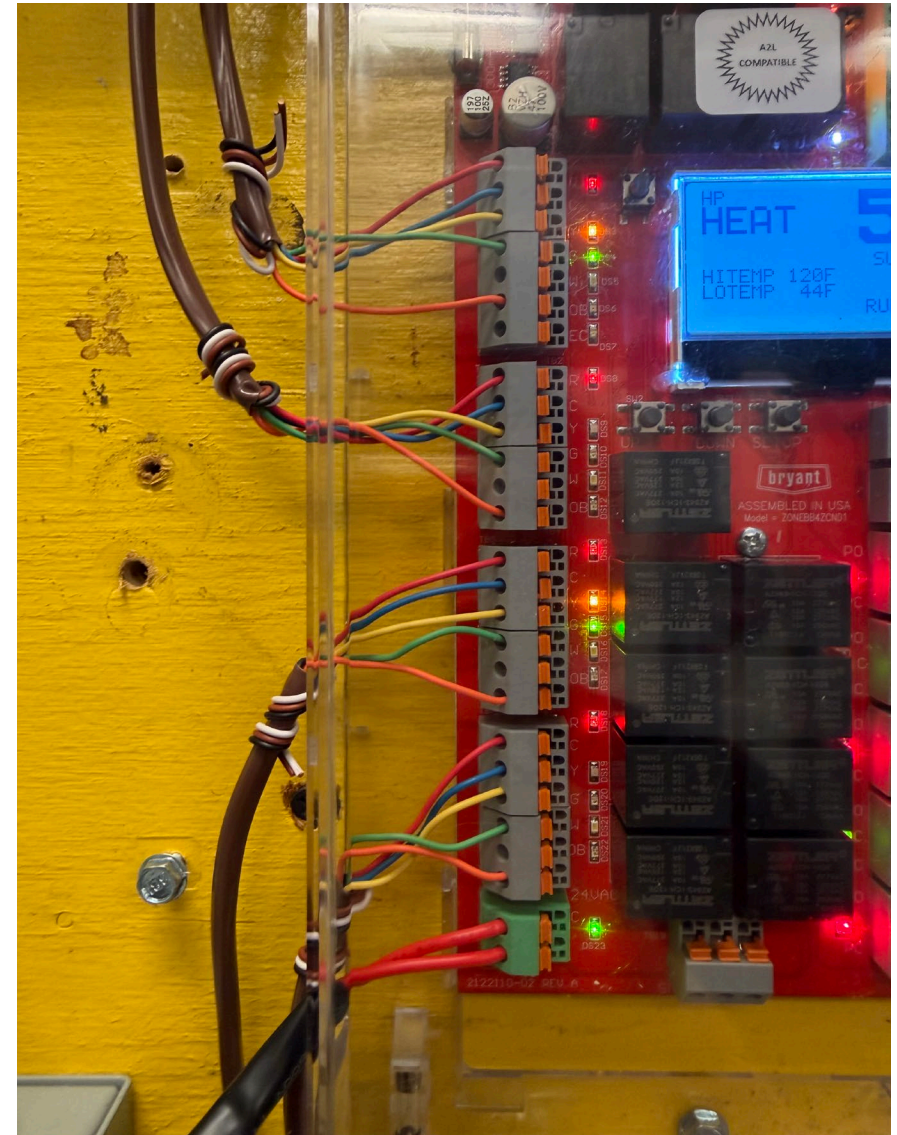

# Transformer Wiring

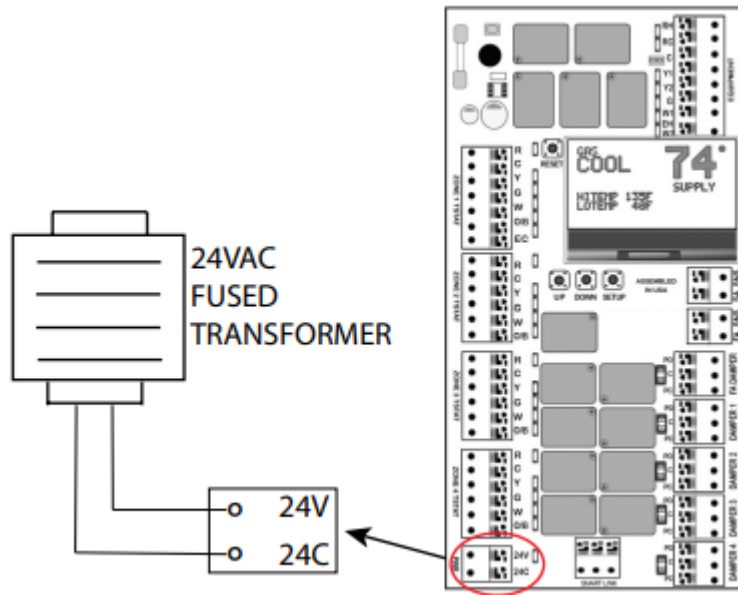

- Top 24V for Hot
- Bottom 24C Common



# Damper Wiring

- Damper requirement to use 18 gauge SOLID Wire.
- Depending on how many damper each Dampers count for 3 VA (PO/PC)
- Example on the right

Table 1 – Ratings

<b>Input Ratings</b>	Voltage: 18-40 VAC 50/60 HZ transformer of 40 VA or more
<b>Current Draw</b>	<ul style="list-style-type: none"> <li>• Zone Controller: 10 VA</li> <li>• PO/PC Dampers: 3 VA</li> <li>• All VA specifications at 24 VAC</li> </ul>
<b>Fuse</b>	5 x 20mm 30 ma Slo-Blo
<b>Temperature Ratings</b>	Shipping: -20° to 150° F Operating: -20° to 165° F
<b>Humidity Ratings</b>	5% to 95% RH non-condensing
<b>Wiring</b>	18-gauge SOLID wire

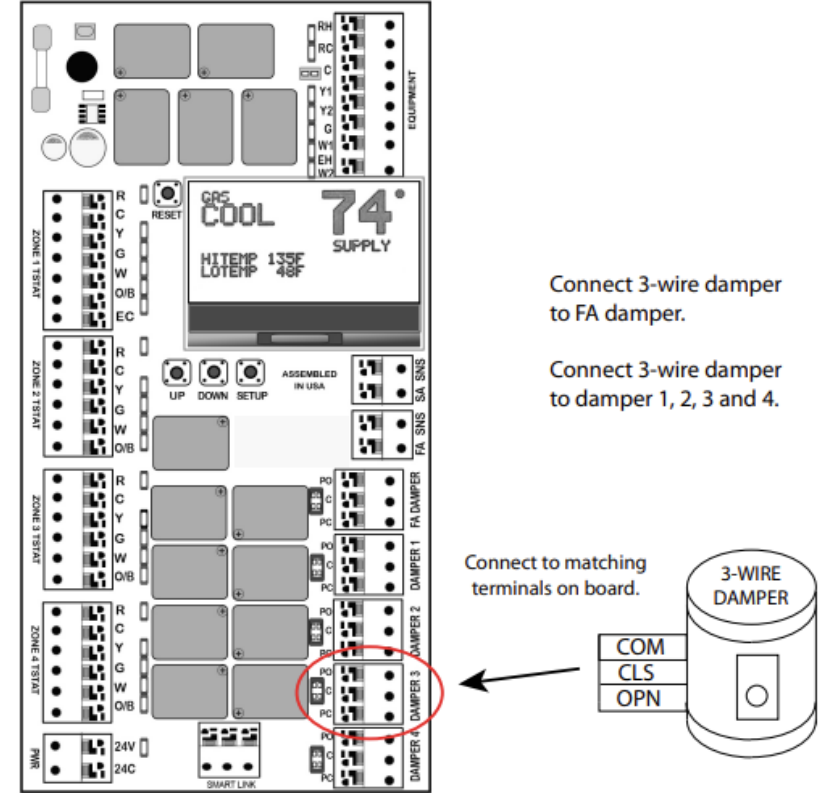
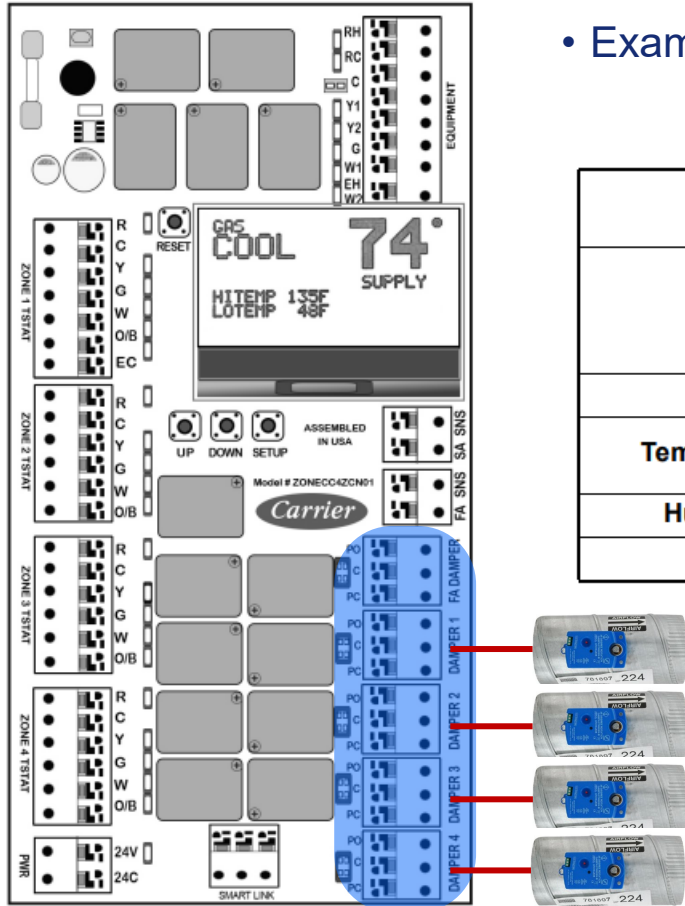

Fig. 3 – Controller Wiring

# Damper Wiring

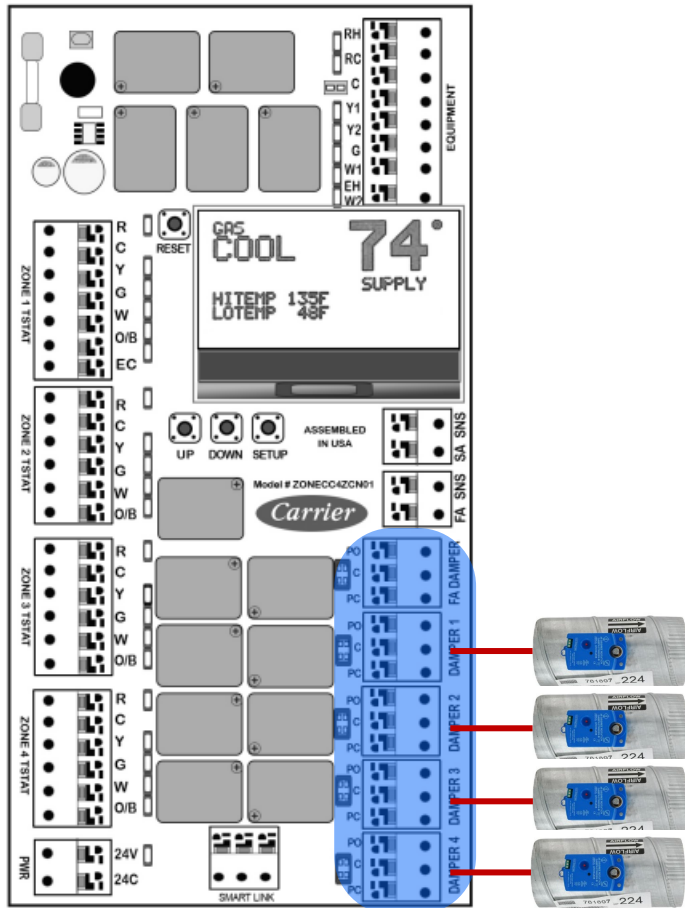
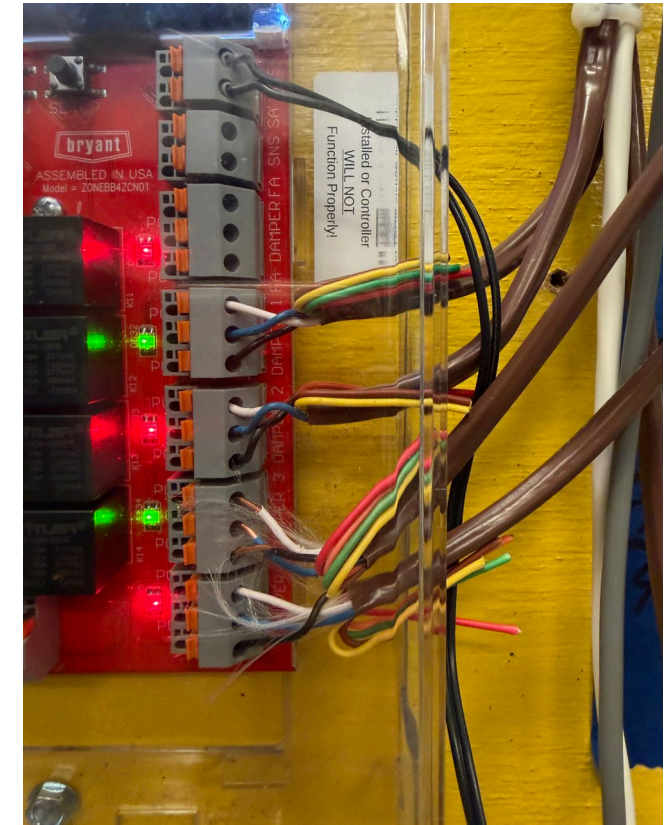

Table 1 – Ratings

<b>Input Ratings</b>	Voltage: 18-40 VAC 50/60 HZ transformer of 40 VA or more
<b>Current Draw</b>	<ul style="list-style-type: none"> <li>• Zone Controller: 10 VA</li> <li>• PO/PC Dampers: 3 VA</li> <li>• All VA specifications at 24 VAC</li> </ul>
<b>Fuse</b>	5 x 20mm 30 ma Slo-Blo
<b>Temperature Ratings</b>	Shipping: -20° to 150° F Operating: -20° to 165° F
<b>Humidity Ratings</b>	5% to 95% RH non-condensing
<b>Wiring</b>	18-gauge SOLID wire



- Damper requirement to use 18 gauge SOLID Wire.
- Depending on how many damper each Dampers count for 3 VA (PO/PC)
- Example on the right

# Best Practices

## Proper System Design

Oversized systems or poorly balanced loads can lead to comfort complaints and equipment inefficiency.

Consider:

- Ensure room-by-room loads are used to calculate system sizing
  - Evaluate south-facing rooms, basements, upper floors, and open-floor plans
- Match zone capacities to system minimum/maximum output to avoid short cycling

## Airflow Management

High static pressure can result in unnecessary equipment wear and noise.

Consider:

- Crossover zoning requires a “dump zone” installation
- Design ducts to handle airflow when the minimum number of zones are calling
  - Low Pressure Systems < .3 in. WC
  - Med. Pressure Systems .3-.6 in. WC
  - High Pressure Systems .6-1.0 in. WC

## Controls Strategy

Reduce call backs with a well-designed controls and damper configuration

Consider:

- Occupancy patterns: bedrooms and living spaces can often be separated, where infrequently utilized rooms can be placed on independent schedules
- Balance the dampers and adjust control settings as needed for optimal comfort and performance.